

Application of Knowledge-Based Techniques to Tracking Function

A. Farina

SELEX Sistemi Integrati
(Formerly AMS SpA)

Director of Analysis of Integrated Systems Group
Via Tiburtina Km. 12.400
00131 Rome
ITALY

e.mail: afarina@selex-si.com

Key words: tracking, knowledge based systems, knowledge based tracker, context data exploitation, A-SMGCS: Advanced Surface Movement Guidance and Control System, GMTI: Ground Moving Target Indication.

1. SUMMARY

This paper describes the application of Knowledge-Based System (KBS) to tracking. Section 2 paves the way to the new technology by discussing the following topics: historical survey of stochastic filtering theory; overview of tracking systems with some details on mono-sensor and multi-sensor tracking, evolution of filtering logics, evolution of correlation logics, and presentation of recent findings on non linear filtering (e.g.: unscented Kalman filter, particle filter) theory which go beyond the classical Kalman filtering. After this introduction to the current state of the art, Section 3 discusses the new technology referred to as “knowledge-based tracker”: a tracker that exploits a-priori knowledge (e.g.: map data) to gain improved performance. Three applications follow: the first refers to the A-SMGCS (Advanced Surface Movement Guidance and Control System) for traffic control on the surface of an airport (section 4); in this case the target tracker is enhanced by exploiting the knowledge of the aerodrome map with runways, taxiways etc. The sensor is a high resolution surface based radar. The theme of section 5 is the tracking of ground moving or stationary vehicles using an airborne GMTI radar. Here we need to take care of the constraints imposed by the terrain (for which only uncertain data might be available), road networks and regions that could be not-trafficable. These information, also in this case, lead to finite support for the distribution of the target state; the classical Kalman filter doesn’t work well and KBS tracker is needed. The last application (section 6) refers to tracking of airborne target masking itself in blind Doppler: these are Doppler frequency bands where the target cannot be detected due to the presence of MTI to reject ground clutter from radar echoes. This is a strategy that the pilot of an aircraft may implement to mask himself to an enemy radar. It is shown that particle filter can fruitfully exploit the a-priori information on blind Doppler thus keeping the probability of target track maintenance at a reasonable level also when the target pursues this masking strategy. An extensive list of references (section 9) is helpful to the Reader for a deeper insight to the many interesting topics of radar.

2. INTRODUCTION

The core of a tracking system is the filtering algorithm. The next section provides some historical notes on the stochastic filtering theory. Then an overview of the state of the art of tracker follows. Also more recent findings on stochastic filtering are discussed.

2.1 Historical Survey of Stochastic Filtering Theory

The well established discipline of estimation theory concerns the problem of deducing the values of a set of unknown parameters from the information given by set of measurements whose values depend on the unknown parameters. As a consequence, it provides valuable solutions to many practical problems in the fields of telecommunications, automatic control, signal and data processing, including tracking with radar and sonar. Estimation theory has its origin in the early work of Gauss [1] and Legendre [2] stimulated by astronomical studies. It was further developed by the contribution of Fisher [3], who introduced the concept of maximum likelihood estimate, and by Kolmogorov's subsequent assessment [4] of probability and random process theory. The relevant work by Wiener [5] introduced and solved the problems of linear filtering and prediction for stationary random processes, described in terms of their power spectral densities; Wiener afforded also the non linear filtering problem [6]. Y. W. Lee, a Ph.D. student of Wiener at MIT did relevant contributions on the explanation of Wiener's theory and tackled various engineering problems related to practical application of the work; for instance, He and His students realised the first analogue correlator machine built in 1940s for calculation of the first- and second-order correlation functions of signals required by the Wiener theory [7]. The mathematical difficulties underlying Wiener's solution motivated the research of a recursive time-domain approach, first by Levinson [8] and then by Kalman and Bucy [9], [10] who approached the estimation problem with modern system theory. They employed the concept of state-transition models for dynamic systems. A fundamental historical and theoretical review of linear filtering, which also provides extensive bibliography, is [11]; for R. Kalman biography see [12]. Probably it is less known the contributions that was given to the theory of stochastic filtering by Peter Swerling; recently Eli Brookner in his book [13] has dedicated an appendix ("Comparison of Swerling's and Kalman's formulation of Swerling-Kalman filters", written by P. Swerling) to this aspect of the stochastic filtering history.

2.2 An Overview of Tracking Systems

Surveillance is typically provided by a network of sensors (heterogeneous or not) (see figure 1): netting is deployed to extend the radar coverage, to increase the opportunity of detection and to increase the robustness of the track. In fact the viewing of a target from different aspect angles tends to reduce target fades, glint and terrain masking effects. In military applications, the possible frequency and spatial diversity, coupled with the ability to triangulate on jammers, provide electronic counter-countermeasure (ECCM) capability. In defence systems especially, various types of radar co-operate with other sensors such as infrared cameras, receivers for passive radio reconnaissance and laser systems. The combination gives rise to the so-called multi-sensor (MST) configuration. Depending on the level at which the merging of data is used, MST can be divided into the two following main classes: distributed and centralised. The distributed architecture (see figure 2) is characterised by the use of a computer at each site performing the mono-sensor tracking function on the measurements of a single radar. The mono-sensor tracks are then transmitted to a single data-processing centre which combines them in order to establish a single multi-sensor track for each target. The centralised architecture (see figure 3) is characterised by the use of a single data processor to which sensor measurements instead of tracks are transmitted from the sites. These measurements are processed so as to obtain a single multi-sensor track for each target. This architecture has the features of: reducing tracking errors because of the higher rate of sampling the target path, improves the robustness of the established track using tracking algorithms with variable data rate, requiring more powerful processing resources. A basic parameter to be

considered in the selection of the architecture and the comparison of performance is the degree of overlap of the sensor coverage. If the degree of overlap is very small, the advantages of the data redundancy are limited, on average, to small areas and few targets. In this case the overall system performance is almost independent of the type of the architecture: thus the selection is mainly determined by the cost.

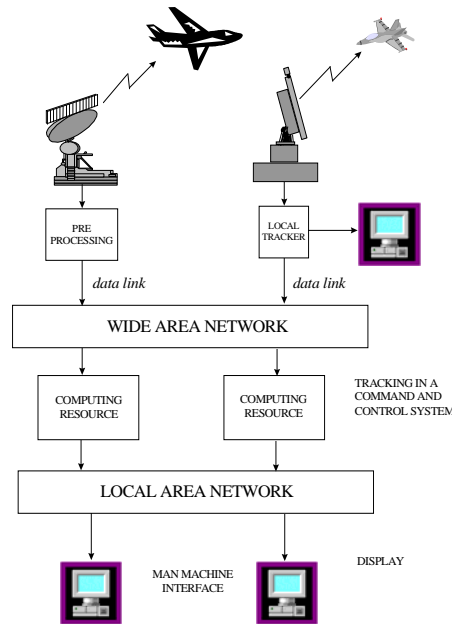

Figure 1

Figure 1: Generic Scheme of a Tracking System.

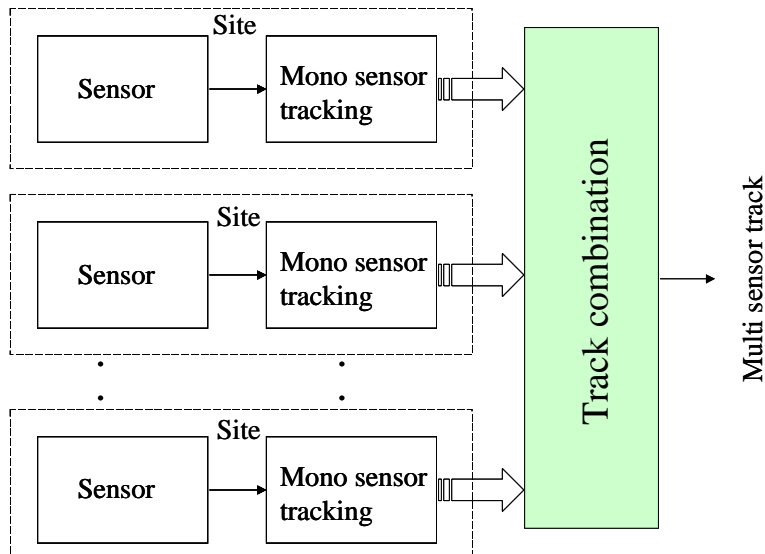

Figure 2: MST with Distributed Architecture.

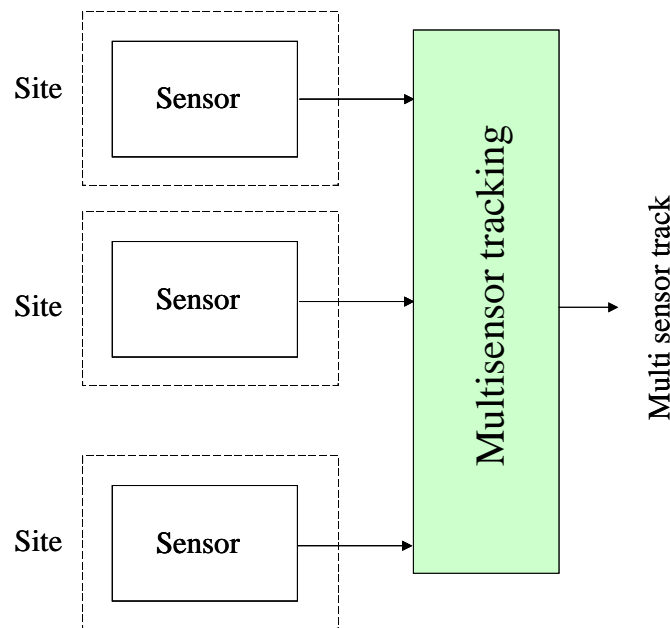

Figure 3: MST with Centralised Architecture.

2.2.1 Mono-Sensor Tracking

In a radar (the sensor mainly considered in this paper) the cascade of signal processor, data extractor and data processor depicted in figure 4 is ultimately a bandwidth compressor. It receives data at a high rate (e.g.: the bandwidth of radar signal, which is in the order of also tens of MHz) and processes the signal in such a manner that a relatively low data rate (several Hz) is achieved. This feature is pictorially indicated by the narrowing of the arrows moving from the left to the right of the cascaded processors. At the same time, there is a progressive discrimination between useful and clutter/interference data, by means of a stepwise decision process. The information handled by the processing chain is progressively manipulated into a form which allows easier decision making by the user. In fact, the raw video signal contains many false echoes. The data extractor isolates the useful target and the data processor identifies the target (possibly labelled with a code), determines the target velocity and additional parameters which are presented on a tabular display. A further observation can be made regarding the increase of the time span in which processing is performed through the cascade. The signal processor involves only few pulses, the data extractor some adjacent groups of pulses and the data processor consecutive radar scans. In other words, the memory of the processing increases on moving from left to right in figure 4 [14].

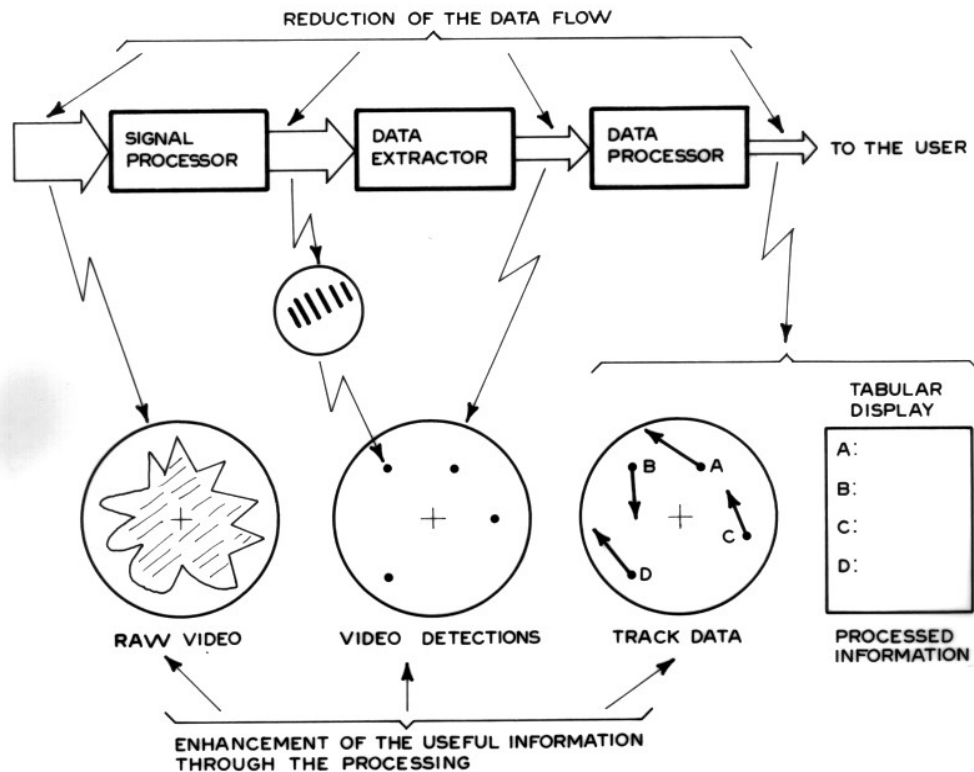

Figure 4: Functions Performed in the Radar Receiving Phase (from Farina, Studer [14]).

In this paper we will focus on tracking which is implemented in the data processor block of figure 4. Tracking, from a classical point of view, can be defined as the set of algorithms which, when applied to the radar detections acquired during successive scans, allows:

- Recognition of a pattern of successive detections as pertaining to the same target;
- Estimation of the kinematics parameters (position, velocity and acceleration) of a target, thus establishing a so-called "target track";
- Extrapolation of the track parameters;
- Distinguishing of different targets, also on the basis of additional attributes (e.g.: IFF: Identification Friend or Foe, shape, electro magnetic signature) and thus establishing a different track for each target;
- Distinguishing of false detections (caused by intentional or natural interference) from true targets;
- Adaptive refinement of the threshold setting of the signal processor in order to make the radar more or less sensitive in the different spatial directions, depending on the content of a map of false detections refreshed on a scan-to-scan base;
- Scheduling of the track dwells of a phased-array radar in order to follow a manoeuvring target with constant accuracy and to interleave in an optimum manner the tracking phases with search looks and other radar functions; and

Application of Knowledge-Based Techniques to Tracking Function

- Efficient managing of the detections and/or the tracks provided by the different radar sets of a netted system looking at the same portion of the controlled space, in order to provide a better picture of the latter.

The working principle of the classical tracking procedure can be explained as follows [14]. Tracking evolves through the following logic steps: track initiation, plot-track correlation, track prediction, track filtering, track termination. The interconnections among these basic tracking functions are shown in figure 5.

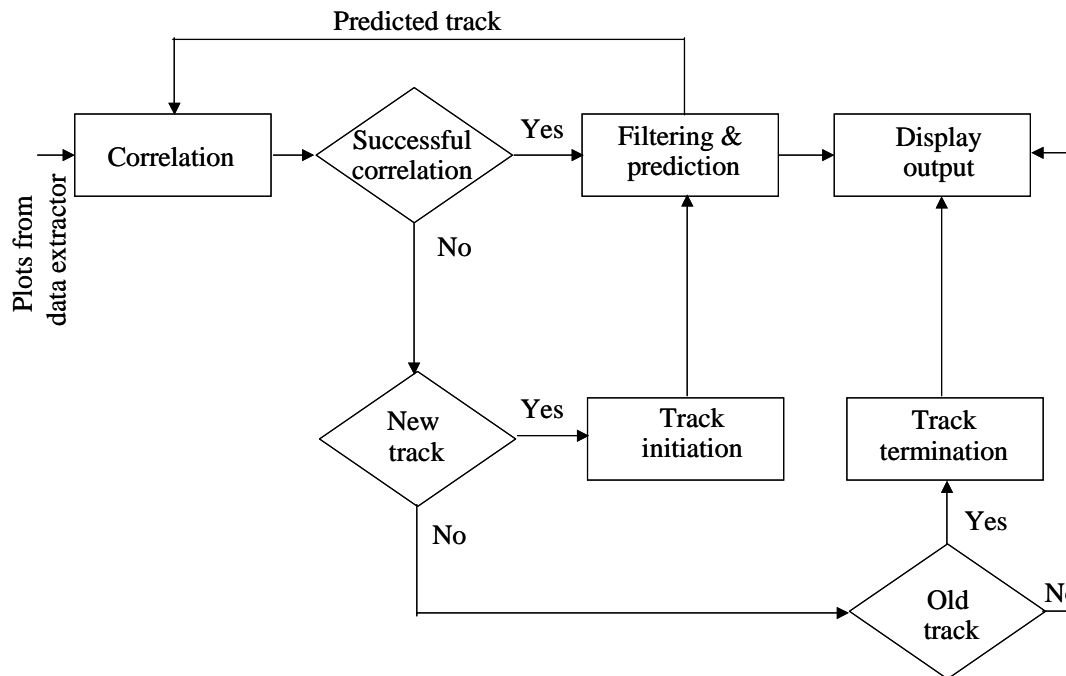

Figure 5: Basic Functions of Tracking Procedure (from Farina, Studer [14]).

First of all a track must be established (track initiation). An estimation of the initial kinematics state of the target (say its position and velocity) can usually be obtained from two consecutive target returns. The target velocity is obtained by the ratio of the position displacement to the radar scan time. This simple procedure is not reliable if false plots are present. It is then necessary to use a longer string of plots to initiate as tracks only those sequences that are consistent with the expected behaviour of target. On the next scan, it is desired, if possible, to capture the return signal from the same target and associate it with the track (plot-track correlation logic). Suppose the target to be moving with constant speed; the position of the target on the next scan can be predicted (track prediction logic) using the current estimates of its position and velocity. However, there may be inaccuracies in these estimates, and there is also a random element due to plot noise in the position at which the plot is expected to occur on the next scan. Thus, in searching for the next target return, allowance for these errors must be made. This can be achieved by deploying a search area centred on the predicted position; a plot found within the search area is associated with the established track. The size of the search area is determined by estimates of errors in position and velocity, as well as by the amount of plot noise. The search area must be large enough to render it highly probable that the next target return will fall inside it. But also, its size should be kept minimal, since if false plots are present, a large search area will on average capture more false plots. This aggravates association problems since in the event that more than one

plot falls inside the search area, it is not known which plot emanates from target. The above search procedure applies only to non manoeuvring target. The approach is simply extended in principle to allow for target manoeuvres. Some limits on target's capacity to manoeuvre are assumed; in the simplest case, this may merely be its maximum acceleration. The manoeuvring capability of target can be expressed as a manoeuvre gate surrounding the predicted position, such that, ignoring effect of estimation and plot noise errors, the target must be found at some point inside this gate on the next scan. There are now two sources of discrepancy between the predicted position and the actual position of the next target plot, namely: that due to estimation errors and noise, and due to possible manoeuvres. The total search area should be formed by allowing for the occurrence of the worst discrepancies from each of these sources – loosely speaking, the noise gate (i.e. the search area used for a non-manoevring target) and the manoeuvre gate are “added” to obtain a final search gate. Assume that the next target plot is successfully associated with the established track. It now remains to update and improve the estimates of the target's position and velocity using the newly acquired plot (track filtering logic). This operation is accomplished by a digital filter which determines the error between the measured and predicted position of plot and presents the smoothed position and velocity of the target at the output. Details on plot-track correlation and filtering logics are given in the following. The evolution of smoothing and correlation logic runs in parallel with the continuous increase in availability of computer processing power.

2.2.2 Evolution of Filtering Logic's

A list of techniques is the following: α - β filter, fixed weights filter, variable weights filter, Kalman filter, IMM (Interactive Multiple Model) filter. The use of fixed-parameter filters avoid the necessity of iteratively calculating new coefficients at every scan and thus greatly reduces the computational load of the filter. This is the first algorithm employed to track a target and, on account of its simplicity, is still used in practical applications, however its performance might be poor. Variable weights filters take into account the prediction uncertainty of the track in its different life stages and generally produce acceptable performance: gains are pre-evaluated and stored in a look-up table so that computational requirements remain low. They assume a constant measurement error and a fixed update interval. The Kalman filter (the successor of the Wiener filter) is a non-stationary filter in which both the estimate and its covariance are described by recursive equations. The Kalman filter can be suitably implemented by a feedback scheme embedding a replica of the system model. Weights are evaluated on line and take into account measurement and prediction errors: the derived load is definitely higher than that of the previous techniques. Adaptivity to sudden changes in the system model (e.g. manoeuvres,..) is a fundamental quality of a filter, i.e. the capacity of providing good filtering of measurement noise (which can be achieved with a narrowband filter) and simultaneously promptness in following sharp manoeuvres (wide bandwidth). Adaptivity at this point requires some kind of manoeuvre detector to determine the onset time of the manoeuvre and heuristics to quickly accommodate the parameters of the filter to the sudden change (see figure 6). When the position displacement d (associated plot – predicted state) is larger than a threshold T (dependent on the noise level), the Kalman filter gain K is suitably increased of a quantity dependent on the displacement. The multiple model (MM) and its more powerful successor, the IMM filter, have intrinsic adaptivity (see figure 7). IMM is a variable bandwidth filter which automatically adapts to target dynamics: it requires the selection of a set of models representative of target motion. The IMM algorithm selects each time the combination of the target models which best fits the measurement data and by appropriate mixing of these different models, each of which is a Kalman filter, it produces the best representation of the target model. IMM has been conceived by H. Blom and Y. Bar-Shalom [15]; further evolution of the theory has produced the variable-structure (VS) IMM [16] which will be used in the following sections 4 and 5.

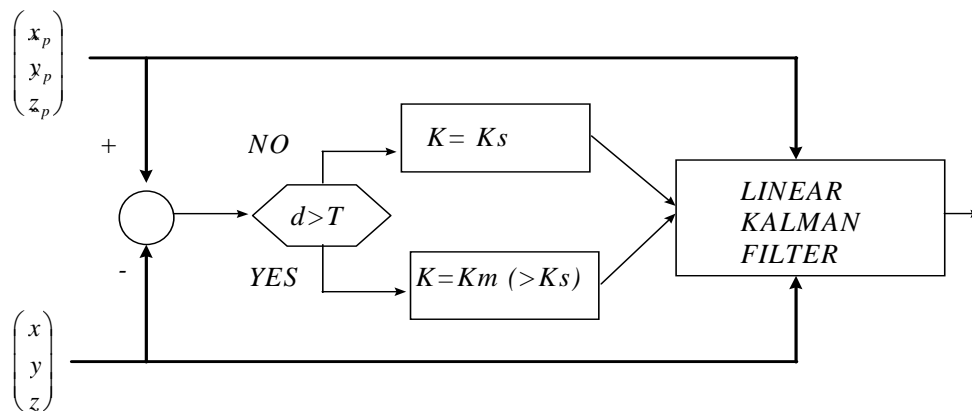

Figure 6: Adaptive Kalman Filter with Manoeuvre Detection Logic.

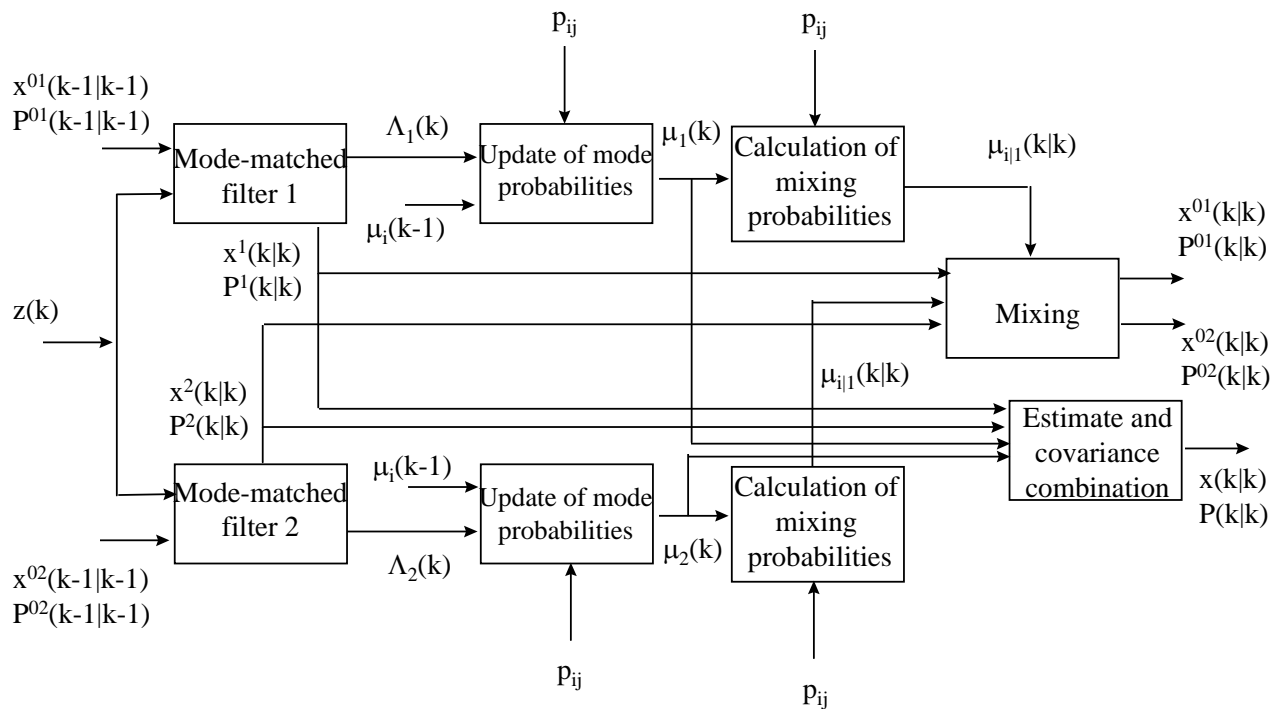

Figure 7: IMM Filter (for details, see [17]).

2.2.3 Evolution of Correlation Logics

A list of techniques is the following: nearest neighbour (NN), local optimum, global optimum, PDA (Probabilistic Data Association), JPDA (Joint Probabilistic Data Association), Multi-scan correlation (MHT: Multiple Hypothesis Tracking). Nearest neighbour solutions are still widely used and attractive for their low computational requirements: a global optimum approach must certainly be preferred. However they suffer from severe drawbacks in dense and noisy environments. JPDA was developed as a way of achieving

acceptable performance in dense clutter environments. Miss-correlation is effectively contrasted by evaluating the probability of each plot-to-track association and then updating the track with a weighted sum of the plots. The approach is time consuming and so many sub-optimal schemes have been developed to reduce its computational load. Multi-scan approaches are certainly the most performant: they allow to defer the final association decision until data relative to subsequent scans is available. They are time consuming since a set of hypotheses over several scans is maintained for each track. Combinatorial optimisation and more powerful processors make multi-scan approaches now feasible.

Most tracking systems in use today employ some type of nearest neighbour correlation and α - β adaptive or Kalman filtering with manoeuvre detection. These logics have been refined and improved through the years and produce a sound and consistent picture of the area under surveillance. In order to exploit the additional processing power now available, sophisticated though time consuming algorithms are being investigated, benchmarked and used in practice. IMM, JPDA, MHT and combinations of these techniques represent the new avenue to pursue. In air defence applications, correlation is the greatest concern. Miss-correlation can completely invalidate the filtering process and so resources should be focused on the data association problem. A computationally intensive MHT algorithm (see figure 8) coupled with simple yet efficient dynamic modelling of target motion has been extensively tested. Manoeuvres are modelled by increasing the process noise of the target model. Several levels of gating are performed to cut down processing time. Results show that the load deriving from an MHT approach can be mastered [17], [18]. In air traffic control applications, correlation is less critical and so resources may be concentrated on the filtering. More accurate modelling of target dynamics (for instance, via IMM and VS-IMM) can improve the kinematics estimates, even though the improvement is dependent on the quality of data.

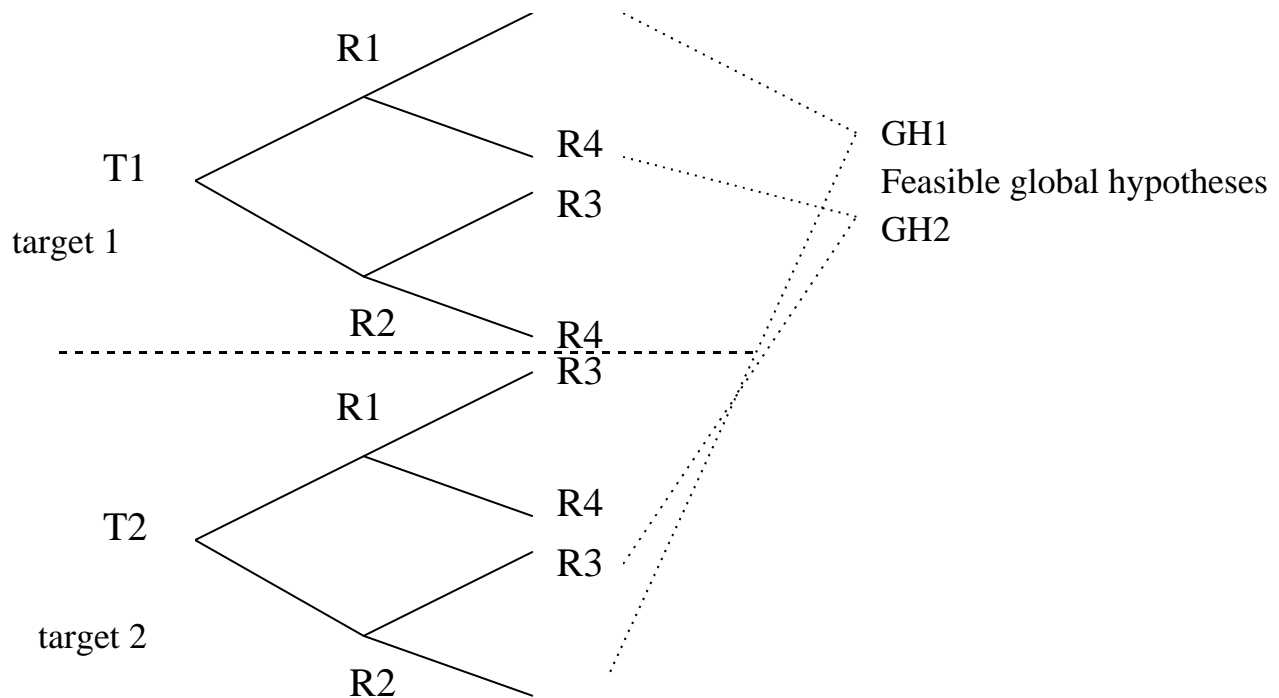

Figure 8: MHT Tree (for details, see [18]).

The performance of the newly-conceived IMM + MHT solution [19], [20] has been investigated: the algorithm seems very promising and its performance should be more than simply the mere combination of the advantages of IMM and MHT, due to the tight coupling of the filtering and correlation components. A diagram of the IMM-MHT tree is shown in figure 9: the tree is a multi-layer tree, with one separate layer for each model of the IMM filter; each layer interacts with all other layers relatively to the same plot according to the IMM logic; multi-layer fusion is enforced, i.e. for each sequence of plots the result is a unique track hypothesis and its scoring is a weighted average of the likelihood at the different layers. The whole IMM + MHT solution provides a flexible framework which can be adapted to the application at a superior level, e.g. in a civilian applications reducing the depth of the multi-scan technique and increasing the number and the modelling of targets and in a defence application the depth of the multi-scan technique can be increased and the modelling made accurate as appropriate. The customisation is also dependent on the available processing resources. IMM plays a relevant role also in the identification phase of surveillance; more precisely, tracking and identification can be jointly performed as explained, for instance, in [21].

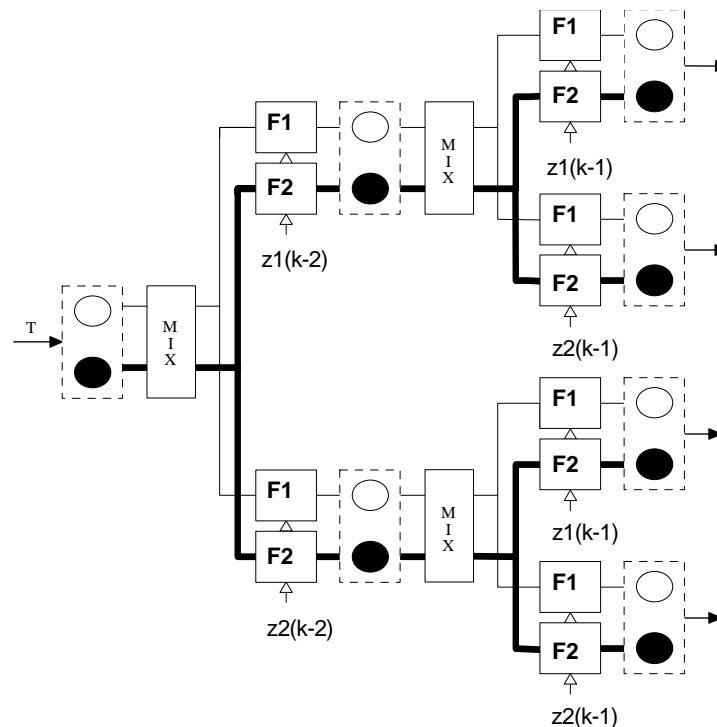

Figure 9: IMM-MHT Tree (for details, see [19] and [20]).

2.2.4 Multi-Sensor Tracking

This is a lively area of research and practical applications. References [22] and [23] illustrate the principle and design of architectures like the ones depicted in Figures 2 and 3. Reference [22] also reports one of the first practical implementations of multi-radar tracking for air traffic control systems in late '70s and early '80s. Application of tracking to multistatic radar systems is described in [24]. More recent investigations dealing with fusion of radar track and ESM (Electronic Support Measures) tracks are reported in [25] to [28].

2.3 Beyond Kalman Filtering

This section illustrates new recent findings in non linear stochastic filtering theory that are beyond the classical Kalman filter theory. Here we summarise recent findings in non linear stochastic filtering theory that go beyond the classical Kalman filtering; these results allow us to deal with filtering problems characterised by non linear dynamic state equations as, for instance, in the case of tracking a ballistic missile on re-entry (see: [29] to [32]) and to tackle non linear measurement equations as, for instance, in the bearings only tracking problem [33]. The general problem of non-linear non-Gaussian has the optimum estimation which requires the calculation of the entire probability density function (pdf) of the dynamic state \mathbf{x}_k conditioned to the whole set of available measurements $\mathbf{Z}_k = \{\mathbf{z}_1, \mathbf{z}_2, \dots, \mathbf{z}_k\}$. To this end one should solve a non-linear stochastic partial differential equation (the Fokker-Plank-Kushner equation); this task is practically impossible except for few cases as the linear-Gaussian that brings to the Kalman filter and the Benes filter [34] which is a truly non linear case. In general, it is necessary to resort to analytical approximation; the most used is the Extended Kalman filter (EKF) which, however, can perform poorly in some cases. A modern and more powerful approximation is the Unscented Kalman filter (UKF); another approach which is truly close to the optimum is the particle filtering (PF). In the following a summary of the UKF and PF is offered.

2.3.1 Unscented Kalman Filter

Similar to EKF, the UKF is a recursive minimum mean square error (MMSE) estimator. But unlike the EKF, the UKF does not approximate the non linear equations (dynamic and/or measurement). Instead it uses the true non linear model and approximates the pdf of the state vector [35]. This density, however, is still assumed Gaussian (in reality it is not, because of non linear dynamics/measurement equations) and is specified by $2n_x+1$ deterministically chosen samples or sigma points (n_x being the dimension of the state vector). The choice of the sigma points guarantees an accurate prediction of the mean and covariance up to the third order for Gaussian priors. The prediction step of the UKF is performed as follows. The unscented transformation [35] first computes the sigma points based on the values of the filtered state vector and the corresponding covariance matrix: $\hat{\mathbf{x}}_{k/k}, \mathbf{P}_{k/k}$. The sigma points are then propagated through the non linear functions and from them the predicted state and its covariance are computed. An application example of UKF is the tracking of ballistic target on re-entry where only the dynamic equation is non linear [29].

2.3.2 Particle Filter

Sequential Monte Carlo (SMC) methods lead to estimate of the complete pdf. The approximation is centred on the pdf rather than compromising the state space model. They are known as particle filters, SIR (sequential importance re-sampling), bootstrap filters, Monte Carlo filters, condensation etc. The PF estimates the entire posterior density of the state vector as it evolves over time. PF has the advantage of being able to handle any functional non linearity and system or measurement noise of any distribution. As the number of random samples used in the filters becomes very large, they effectively provide an exact, equivalent representation of the required pdf. Estimates of moments (such as mean and covariance) or percentiles of the state vector pdf can be obtained directly from the samples. The MMSE estimate is then calculated as the mean of the posterior density. The central idea is to represent the required density by a set of random samples (particles) [36], [37]. As the number of particles grows to infinity, the representation of the required density becomes exact. In practice we work with a finite, preferably small number of particles, and the optimality of the PF is lost. Nevertheless in many practical applications the PF has demonstrated superior performance compared to other non linear filters [32] and [38]. Let the posterior density $p(\mathbf{x}_k, \mathbf{Z}_k)$ be represented by a set of random samples (particles) $\mathbf{X}_k = \{\mathbf{x}_k(i) : i = 1, 2, \dots, N\}$. The PF is an algorithm which propagates and updates the set \mathbf{X}_k to a

new set of random samples \mathbf{X}_{k+1} which is approximately distributed as the posterior density $p(\mathbf{x}_{k+1}, \mathbf{Z}_{k+1})$. The particular PF scheme we have tested, for instance in [32], is based on the sequential importance re-sampling scheme [36] with the regularisation step to avoid impoverishment problem [39]. In the prediction step, all the N particles from \mathbf{X}_k are passed through the state equation. The weights associated with each predicted particle are computed as the normalised likelihood based on the observation \mathbf{z}_{k+1} . In the re-sampling step, the predicted particles are jittered using the Epanechnikov kernel and selected with the probability equal to their weights [39]. Note that for the case of non linear dynamics and linear measurements (as in the case of tracking a re-entry ballistic target), one could design a more efficient PF based on the optimal importance density [37]. Note also that the KF corresponds to (one) particle filter. Other examples of PF applications are: tracking in clutter, tracking with intermittent decoys, group target tracking, bearings only tracking, multiple target tracking and data fusion [40], etc. Some of the PF capabilities are: the algorithm is parallelisable, incorporates realistic models, incorporates prior and context information (terrain shadowing, manoeuvre capabilities), integrates with decision processes [41]. One problem that the PF has is the computational load much higher than the one related to EKF and UKF. To have a flavour of the computational load of PF with respect to EKF and UKF refer to the tracking of ballistic target [29]. A thorough analysis of the computational load of PF and how to mitigate the curse of dimensionality with a careful design of PF is reported in [42].

2.3.3 Cramer-Rao Lower Bound for Non Linear/Nongaussian Filtering Problems

Non linear filters based on approximations generate estimates which are more or less affected by these approximations and deviate from the ideal exact solution. Quality evaluation of the non linear filters is a complex problem of non linear estimation. The knowledge of a lower bound for the mean square error of an estimate can give an indication of estimator performance limitations, and consequently it can be used to determine whether imposed performance requirements are realistic or not. It can also assist in ranking the approximated solutions at hand. Cramer-Rao (CR) bound, defined as the inverse of the Fisher information matrix is an extremely useful tool in the estimation of constant and deterministic parameters. The CR bound can be applied also to the estimation of random parameters. More relevant is a recent result which refers to the recursive calculation of the CR for stochastic processes in the frame of non linear/non Gaussian filtering theory [43]; an extension of the theory also to dynamic systems with unknown parameters is described in [44]. A further extension to the case in which the measurement is achieved with detection probability less than 1 is reported in [45]. Applications of this theory to practical filtering problems are described in [34] and [29] to [31].

2.3.4 References on Tracking

A number of key texts to which the Reader can refer for deeper analysis on target tracking are the following. In addition to [14] and [22], perhaps the first text on target tracking, more recent books are [46] to [50] just to mention a few. Publications on tracking frequently appear on the Trans. of IEEE-AES, on the Proc. of IEE-RSN and on Information Fusion (Elsevier). Conferences that contain papers on tracking are those on radar organised by IEEE and IEE; also the recent series of "Fusion" conferences promoted by the International Society for Information Fusion (ISIF) is rich of such type of papers.

3. KNOWLEDGE BASED TRACKER

Let distinguish between tracking of ground moving targets and tracking of flying targets (aircraft, helicopters, etc.). Theory and application examples are developed for both cases: Sections 4 and 5 are devoted to tracking

of surface moving targets, while Section 6 refers to tracking of aircraft. Prior information that can be exploited are map features used to predict shadowed areas in the target flight path, to compute the likelihood of a target manoeuvre to avoid known obstacles (e.g.: turns to avoid elevated terrain) and correlate target paths with road and rail maps. Shadow regions may be due to jamming, line of sight blockage, severe clutter, ground traffic, tangential target velocity (i.e.: portion of track perpendicular to radar line of sight to create zero Doppler region, see Section 6), etc.

The intelligent control of surveillance radar system has great potential in many aspects such as resource allocation and management, signal processing and tracking [51]. Air Force Research Laboratory in US has been among the first R&D institution to prove in 1989 the efficacy of knowledge based tracker (KBT) showing improved tracking performance through the use of external knowledge sources. The KBT receives detections, target, clutter, jammer and contextual information: these are exploited to select track filtering algorithms and correlation gates. One question of interest is to which degree the knowledge about local radar environment could enhance the ability of the tracking processor to maintain multiple tracks through areas of shadowing, clutter and other sources of interference. Also it is important to define knowledge-based rules for the KBT. Both questions have been answered by Air Force Research Laboratory in US; here we report a brief account of some of the findings described in [51], [52] and [53].

KBS allows us to use *proactive tracking* in lieu of classical *reactive tracking*. Proactive tracking anticipates target manoeuvres due to obstacles, coasts tracks in shadowed regions, identifies possible ground moving targets and clutter discrete. A manoeuvre anticipation rule was developed and tested using a priori map information of target's proximity to an obstacle, 1g manoeuvre was added into tracker's plant covariance matrix several scans before the tracker would normally respond to the target's manoeuvre. The resulting performance of proactive tracker was seen to be superior to the normal reactive tracker operating on the same data. Not only were the peak, mean and standard deviation of tracking error smaller, but the stability of the proactive filter was also better [51], [52] and [53]. In more general terms, the proactive tracker uses information from sources such as digital terrain maps, radar clutter and interference maps, and target priority assessments to determine the nature of the threat, evaluate the local environment, anticipate the target's actions, and enhance the prediction of target's location for the next radar observation. A conventional tracker reacts to target manoeuvres, missed detections etc. As a consequence, there can be significant errors in the predicted target location, especially when manoeuvres occur. Additionally, the uncertainty ellipsoid about the predicted target position will become large if data-to-track association cannot be made. This will result in correspondingly larger target acquisition windows for subsequent scans, which can cause incorrect data-to-track associations and susceptibility of false alarms, and will require the use of additional radar resources for maintaining target tracks. Here a comparison between reactive and proactive trackers. The reactive tracker is characterised as follows: uncertainty ellipses remain small before manoeuvre begins, position errors become large during target turns, manoeuvre gate is triggered by poor prediction of target location, Kalman filter gain remains high for significant length of time. As opposite the proactive tracker is characterised as follows: Kalman filter gain is increased earlier manoeuvre begins, ellipse area is initially larger than for reactive tracker, there is a quick recovery after manoeuvre. Rules are also developed for multi-target association logic. In the case of proactive tracker the association logic uses local environment data and includes manoeuvre hypothesis; in the case of reactive tracker the association logic normally uses the nearest report assignment for the track [51], [52] and [53].

Concerning the correlation gates, three types have been devised. 1st type: single elliptical gate centred on the predicted point and oriented along range/cross-range. Its size depends on both measurement error and selectively injected manoeuvre noise that is added to the prediction covariance matrix. Association occurs when the measurement falls within the gate. 2nd type: two gates are used: a measurement gate (oriented along

range/cross-range, its size depends only on measurement noise) and a manoeuvre gate (oriented along track/cross-track, its size depends only on the prediction covariance matrix). Association for this case occurs when the measurement falls inside either gates. 3rd type: it is similar to the 2nd type with the exception that measurement gate is positioned on the measured data point and manoeuvre gate is centred on the predicted position. Association occurs when the measurement ellipse intersects the manoeuvre ellipse.

The following data are available to KBT: measured target coordinates, target priority, digital topography and terrain cover maps with road overlays and locations of large stationary discrete, clutter maps generated by the radar providing absolute clutter-to-noise power ratio data and detection threshold relative to system noise level overlays, radar parameters, tracking data from other sensors (including radar, IFF, ESM, GPS). These data are stored in a data base which is dynamic because the data will change with time and need to be updated.

The KBT functional flow is sketched as follows [51], [52] and [53]:

- 1) Detection validation: test for discrete, ground traffic, etc. from map information of highways, railways, digital terrain models and geographic information system.
- 2) Potential manoeuvre contour: determine locus of points that defines physically possible target manoeuvres.
- 3) Anticipated manoeuvre conditions: evaluate data base to identify conditions for which target manoeuvre will probably occur. Adopt KBT by increasing filter gain prior to manoeuvre.
- 4) Deterministic manoeuvre conditions: evaluate data base to identify conditions for which manoeuvres must occur. Position data-to-track association windows accordingly.
- 5) Coast/demote track state: base decision for state demotion on data base information (CFAR level, obscuration, etc.).
- 6) Update data base: performed at end of every radar scan.

Here an example of few (out of some tens) knowledge based rules. *Manoeuvre/obstacle rule*: both α - β and Kalman filters do a good job with targets that move along a constant heading with a fixed speed. Deviation from a straight path cause prediction errors to occur and can ultimately result in a dropped track. Therefore it is important, whenever possible, to anticipate target manoeuvres by several scans. This allows time to make such adjustments as increasing the gate size and filter gain, or using shaped gate to allow for across track deviations cause by target turning. If a target approaches an obstacle whose across-track extent is H , a manoeuvre can be anticipated to occur within a time extent no longer than T_{max} . Assume a constant target speed v and a maximum possible acceleration A_{max} , this extent is: $T_{max} = \frac{\rho}{v} \cos^{-1}(1 - \frac{H}{\rho})$ where $\rho = \frac{v^2}{A_{max}}$ denotes

the radius of curvature of a target turn required to clear the obstacle. Somewhere within this time period the tracker should apply its manoeuvre logic. *Shadow rule*: provides a means of preserving firm tracks that enter regions shadowed from radar line of sight. If the predicted track gate centre falls within a designed shadow region, both the track state and the gate size are frozen. Upon emerging from shadow the state promotion resumes and the gate size will not be allowed to exceed a maximum value. *Discrete rule*: by tagging large radar returns, or discrete, the radar processor can exclude regions containing them from its covariance matrix element formation and thereby not use up limited degrees of freedom on their cancellation. The discrete rule allows the tracker to coast through any region containing one of these tagged returns and to essentially ignore it. If a known discrete falls within a track gate, that track will be treated as if in a shadow and will not be updated.

The performance of KBT are measured by: number of correct tracks, number of dropped tracks, number of incorrect tracks. Based upon these numbers and the contextual data the KBT will adjust its rules and thresholds to increase its performance. A suitable knowledge based controller incorporates software to dynamically update the knowledge domain data base to indicate object identifications and level of confidence and to extract features.

The KBT provides the system's knowledge based controller with:

- 1) A very accurate prediction of each target's location and kinematics for an ensuing radar dwell; and
- 2) Knowledge of target's line of sight visibility, the competing clutter conditions and interference at the predicted location so that the optimal radar parameters and adaptive processing algorithm can be applied.

4. APPLICATION TO A-SMGCS

The Advanced Surface Movement Guidance and Control System (A-SMGCS) is an integrated airport management system consisting of different functions (surveillance, control, guidance and routing) to support the safe, orderly and expeditious movement of aircraft and vehicles on aerodromes under all circumstances with respect to visibility conditions, traffic density and complexity of the aerodrome layout. Figure 10 depicts the scheme of a generic A-SMSGCS with several heterogeneous sensors (radar, GPS, multilateration) to acquire kinematical and feature information on moving aircraft and vehicles (bus, car) on the surface airport.

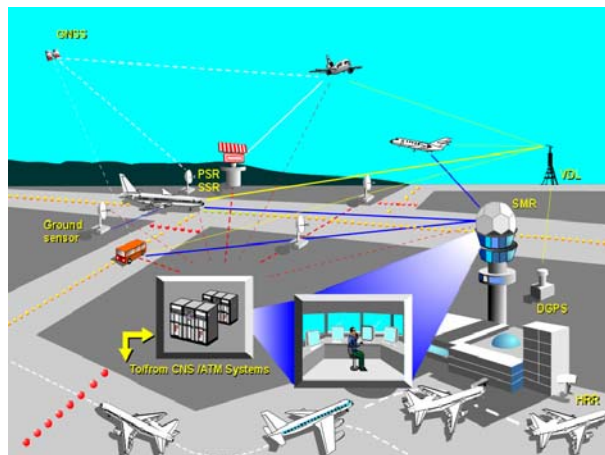

Figure 10: A-SMGCS in a Multi-Sensor Context.

Surveillance function is an essential element of any A-SMGCS. A combination of visual surveillance, Surface Movement Radar (SMR) and voice messages is currently used by controllers to monitor all movements. The monitoring of aircrafts and vehicles is also currently a significant function performed by pilots and vehicle drivers. As visibility reduces, the ability of controllers and pilots to carry out visual surveillance becomes increasingly impaired. Problems for controllers become significant when the movement area cannot be adequately seen from the control tower. For pilots and vehicle drivers their capability becomes seriously impaired when the visibility falls below 400 m. Improvement of surveillance function to overcome the above mentioned problems is one of the key requirements of an A-SMGCS. The surveillance therefore should

Application of Knowledge-Based Techniques to Tracking Function

provide identification and accurate positional information of all movements in the area, consisting of apron (area on an airfield for manoeuvring or loading), the manoeuvring area and runway strip.

The above surveillance requirements are challenging because of the A-SMGCS environment: airports have many obstacles that might block the line of sight causing blind spots and shadows, there are different targets (aircrafts and ground vehicles), different target dynamics, minimal distance between targets, presence of ground, weather and angel clutter (e.g.: due to slow moving flocks of birds), presence of spurious phenomena like multipath, target glint, reflections (typical reflectors are ground obstructions such as aircraft hangars, apron and terminal areas, buildings, towers and adjacent hills or mountains) and target echoes from cars and trains on the roads and railways close to the airport. In this scenario a traditional ATC (Air Traffic Control) tracking algorithm [14] is not sufficient to avoid the growth of false tracks (generated by false plots), ghost tracks (tracks initiated on object target reports and updated with false target reports), swap tracks (tracks updated with plots corresponding to a different object, which occur when two or more objects are in close proximity) and flying angel tracks (primary radar echo caused by a moving atmospheric refraction, atmospheric inhomogeneity, insects, birds etc.).

For these reasons, the tracking algorithm of the A-SMGCS needs to be improved, and the following steps are tackled: upgrade the single sensor tracking algorithm; improve the multi sensor tracking performance by a suitable fusion of the data provided by the different A-SMGCS sensors deployed in the aerodrome. This section illustrates an enhancement of the single sensor tracking algorithm. The upgrade is based on the exploitation of the knowledge of airport map data into the tracking algorithm itself. In an airport, the radar targets (aircraft, vehicles) move along the road and runway network. The result is a constrained target kinematics depending on the target state: i.e. when the target is on the airport surface, its position indirectly contains also some kinematical information; this knowledge can be exploited by the tracking algorithm to reduce the uncertainty of the target state and consequently to improve the accuracy of the predicted target state.

The tracking algorithm can then include the road local configuration to improve the tracking prediction phase ([54], [55]). To include constraints, the Interactive Multiple Model (IMM) approach can be considered ([17], [20] and [56]). The IMM enriches the class of Multiple Model (MM) approach to tracking. The MM methods are based on the fact that the behaviour of the target cannot be properly characterised by only one model during all the time; rather, a finite number of different models should be taken into account. The interaction between the different models is controlled by a transition probability matrix.

However, the constrained IMM approach to the A-SMGCS tracking brings to the simultaneous use of large number of different models because of the complexity of the road network and of the possibility of several different target manoeuvres on the whole airport area. If the constraints due to the road network are used, the classical IMM approach is not suitable, because it brings two problems:

- i) If the number of models is too high, the IMM does not work properly because the interaction between the models induces a sensible performance degradation; and
- ii) The computational load grows with the number of models and it could be unaffordable.

A Variable Structure IMM (VS-IMM) ([16], [54] and [57]) can be used to overcome these two problems. The VS-IMM algorithm is an IMM with a variable set of models and a variable transition probability matrix. The set of models and the transition probabilities of the VS-IMM are updated taking into account the map of the airport and the tracking estimation of the previous step. Each model has associated a section of the airport area in which it is active and, during the tracking of a target, only a few models corresponding to the possible

local kinematics are active, reducing the performance degradation due to the model interactions and the computational load of the classical IMM algorithm.

A VS-IMM tracking algorithm, based on the knowledge of the road network of the airport, has been considered in a realistic simulated A-SMGCS scenario; in [58] it has also been applied to real data recorded in the Malpensa (It) airport. The performance of the VS-IMM has been compared to the ones obtained by other tracking approaches, like the classical EKF (Extended Kalman Filter) and two IMM algorithms with different number of constrained models.

4.1 Unconstrained Tracking

The state vector $\mathbf{s}(k)$ of the EKF includes the position of the target in the Cartesian coordinates, the velocity in the polar coordinates and the turn rate:

$$\mathbf{s}(k) = [x(k) \quad y(k) \quad v(k) \quad h(k) \quad \dot{h}(k)]^T \quad (1)$$

where x and y represent the target position, v is the module of the velocity, h is the heading and \dot{h} is the turn rate. Technical literature shows that the choice of this set of variables brings to good performance [59]. The target kinematics is represented by the following system of discrete time not linear equations:

$$\begin{aligned} \mathbf{s}(k+1) &= \mathbf{A}(\mathbf{s}(k)) \cdot \mathbf{s}(k) + \mathbf{w}(k) \\ \mathbf{z}(k) &= \mathbf{H} \cdot \mathbf{s}(k) + \mathbf{n}(k) \end{aligned} \quad (2)$$

where: $\mathbf{A}(\mathbf{s}(k))$ is the following not linear transition matrix (T is the radar scan time):

$$\mathbf{A}(\mathbf{s}(k)) = \begin{bmatrix} 1 & 0 & \cos(h(k) + \dot{h}(k) \cdot T) & 0 & 0 \\ 0 & 1 & \sin(h(k) + \dot{h}(k) \cdot T) & 0 & 0 \\ 0 & 0 & 1 & 0 & 0 \\ 0 & 0 & 0 & 1 & T \\ 0 & 0 & 0 & 0 & 1 \end{bmatrix} \quad (3)$$

\mathbf{w} is a vector representing the total uncertainty on the target kinematics, which it is assumed dependent on the module of the target velocity, the heading and the turn rate. In the simulations reported in the article, the following values of the uncertainties have been chosen:

$$\sigma_v = 1 \text{ m/s} \quad \sigma_h = 2^\circ \quad \sigma_{\dot{h}} = 1^\circ/\text{s} \quad (4)$$

the standard deviations on x and y are derived by equation (4); \mathbf{z} is the measurement vector; \mathbf{H} is the matrix that relates the state to the measurements:

$$\mathbf{H} = \begin{bmatrix} 1 & 0 & 0 & 0 & 0 & 0 \\ 0 & 1 & 0 & 0 & 0 & 0 \end{bmatrix} \quad (5)$$

and \mathbf{n} is the measurement error with zero mean and a suitable covariance matrix [14].

4.2 Constrained Tracking

Constraints can be implemented by imposing relationships between the state variables. There are several ways of doing this; in this study the method presented in [55] has been selected. This method consists in modifying the prediction phase of the models used by the IMM algorithm in such way that a suitable relationship between the state variables is satisfied:

$$\mathbf{C} \cdot \mathbf{s}(k) = \mathbf{c} \quad (6)$$

The unconstrained EKF presented in the previous section has been modified introducing the following constraints based on the local road configuration:

- 1) if the road is straight and forms an angle θ_0 with the x-axis, the equation (6) becomes:

$$[0 \ 0 \ 0 \ 1 \ 0] \cdot \mathbf{s}(k) = \pm \theta_0 \quad (7)$$

where the choice of the sign depends on the crossing direction;

- 2) if there is a curved path with curvature radius R, the equation (6) becomes:

$$[0 \ 0 \ 1 \ 0 \ \pm R] \cdot \mathbf{s}(k) = 0 \quad (8)$$

where the choice of the sign depends on target turn which may be clockwise or counter clockwise.

4.3 IMM and VS-IMM

The IMM tracking algorithm uses a set of M state equations, corresponding to M different models, in parallel during the prediction phase:

$$\begin{aligned} \mathbf{s}_m(k+1) &= \mathbf{A}_m(\mathbf{s}_m(k)) \cdot \mathbf{s}_m(k) + \mathbf{w}_m(k) \\ \mathbf{z}_m(k) &= \mathbf{H}_m(k) \cdot \mathbf{s}_m(k) + \mathbf{n}_m(k) \end{aligned} \quad m = 1, \dots, M \quad (9)$$

where the m indicates one of the hypothesised target models. The interaction between the models of the IMM is managed by a Markov chain represented by a matrix whose elements are the probabilities p_{ij} of switching from model i to the model j (transition probabilities):

$$\mathbf{P}_T = \{p_{ij}\} = \{P\{m = j \mid m = i\}\} \quad (10)$$

The IMM algorithm is divided in four phases: interaction, prediction, filtering and combination. In the interaction phase, the solutions of each model corresponding to the previous step are mixed to form the initial states of the IMM models; the mixing is performed taking into account the mode probabilities and the transition probabilities p_{ij} . In the prediction phase, the transition matrix of each model is applied to the initial state to obtain a new set of predicted states. Each predicted state is then filtered using the residual error, that is the difference between prediction and measurement. The mode probability is calculated by means of the likelihood value, that is derived by the residual error probability density function assuming it is Gaussian. The estimated state of the whole IMM tracking algorithm is finally obtained by linearly combining the filter estimated states of all the models; each state is weighted by the corresponding mode probability.

The IMM algorithm uses a fixed set of models and fixed transition probabilities. The VS-IMM instead has a variable set of models and variable transition probabilities: model set and transition probability up-date phase precedes the interaction [54]. This phase is based on the estimation of the target state of the previous algorithm step and on the map of the area controlled by the radar. All the state variables can be exploited in the above mentioned phase; here only the target position has been considered.

4.4 Simulated Scenario

Figure 11 shows a section of the Venice (It) airport selected for the simulation. It includes two runways and three taxiways; each of them labelled with a number. In the considered scenario an aircraft has just landed and it is going from runway 2 to the apron. The route and kinematics of the aircraft is as follows: it moves along runway 2 with an acceleration of -2 m/s^2 ; it successively performs a manoeuvre with a turn rate of about $1^\circ/\text{s}$ entering taxiway 1 with 5 m/s of speed; it moves along taxiway 1 with a 5 m/s velocity; it then performs a manoeuvre with turn rate of about $4.4^\circ/\text{s}$ entering taxiway 2; it crosses the runway 1 entering the taxiway 3 with a 5 m/s velocity uniform motion and it finally moves along taxiway 3 with a 5 m/s constant speed.

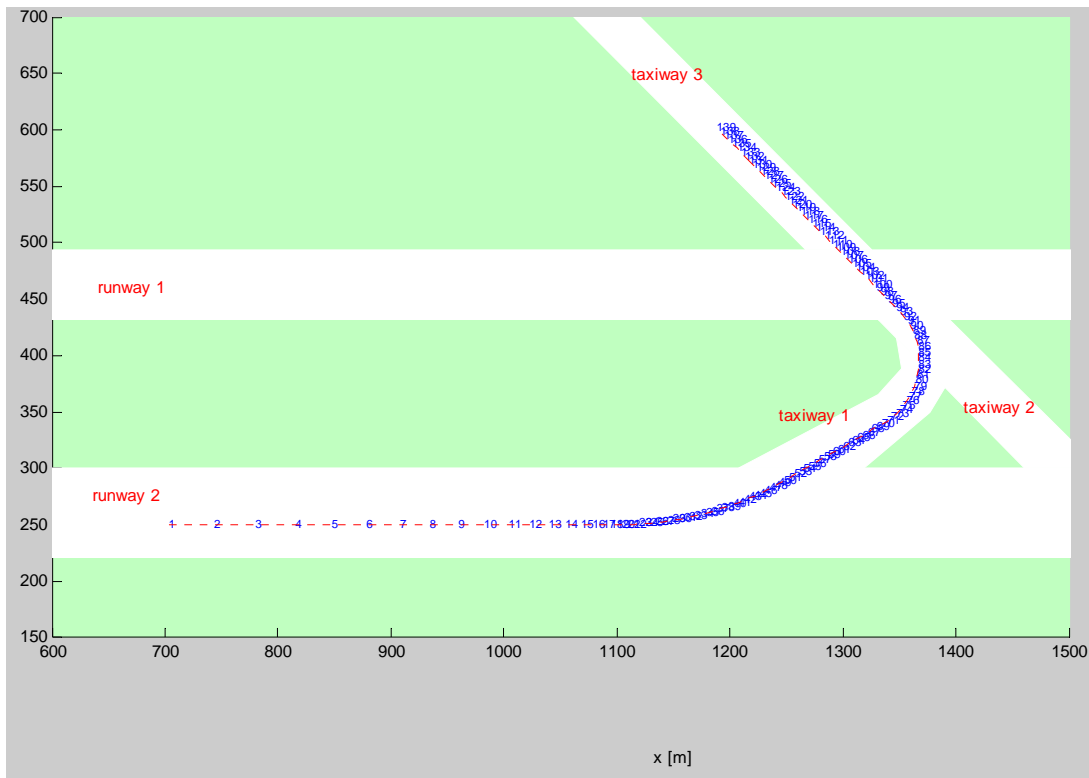

Figure 11: Simulated Trajectory of Landed Aircraft going to Apron (section of Venice (It) airport).

An SMR with a scan time $T=1 \text{ s}$ intercepts the aircraft in the points of trajectory reported in Figure 11. Each point is labelled with a number indicating the radar frame in which the trajectory point is intercepted. Random noise has been added to the measured position to simulate the extraction of the radar raw data. A standard deviation of 10 m for the range measurement and of 0.2° for the azimuth one have been considered.

4.5 Simulation Results

The following tracking algorithms have been considered:

- An EKF without constraints;
- An IMM with four models: three constrained ones matched respectively to runway 2, taxiway 1 and 3 and an unconstrained one for the manoeuvres;
- An IMM with seven models: three constrained ones matched respectively to runway 2, taxiway 1 and 3; two constrained ones matched to the manoeuvres effectively performed by the airplane during the trajectory; a constrained one matched to a centripetal manoeuvre that the airplane will not perform (“not performed manoeuvre”) and, finally an unconstrained model; and
- A VS-IMM with the same seven models of IMM, whose map-based activity areas are shown in Figure 12: the model matched to runway 2 is active in the area 1; the one matched to taxiway 1 is active in the area 3; the one matched to taxiway 3 is active in the area 5; the one matched to the first airplane manoeuvre is active in the area 2; the one matched to the second airplane manoeuvre is active in area 4; the model matched to the “not performed manoeuvre” is present in the bank of filters but is never active in the considered airport section (it might be active in another section); the unconstrained model is always active.

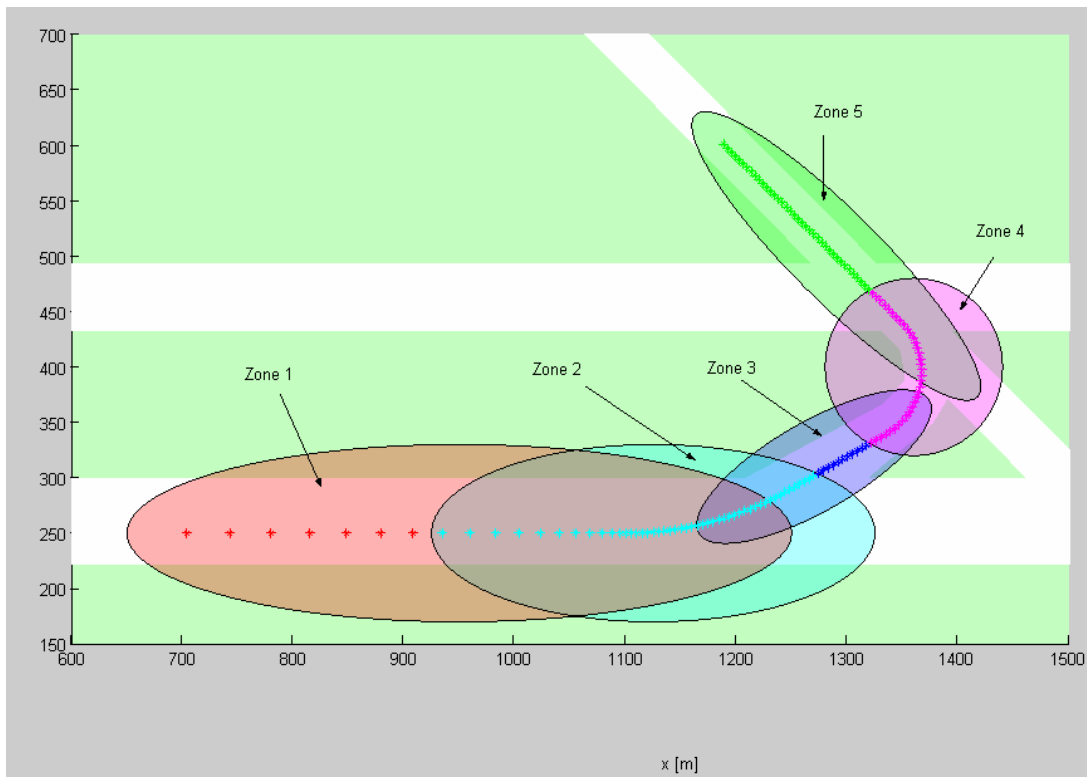

Figure 12: Areas in which the VS-IMM Modes are Active.

The accuracies of the estimated target states obtained by the tracking algorithms have been compared by averaging the results of 10000 independent Monte Carlo trials. Figure 13 shows the mode probabilities of the

IMM with four models. The point marked, the cross marked and the circle marked curves correspond respectively to the models matched to runway 2, taxiway 1 and taxiway 3; the asterisk marked curve is associated to the unconstrained model. It can be seen that there is a correct behaviour of the IMM; the tracking algorithm in fact uses the models that best approximate the target kinematics along the trajectory. In particular, because the IMM has not constrained models matching the two manoeuvres, during such part of the trajectory the tracking algorithm uses the unconstrained model.

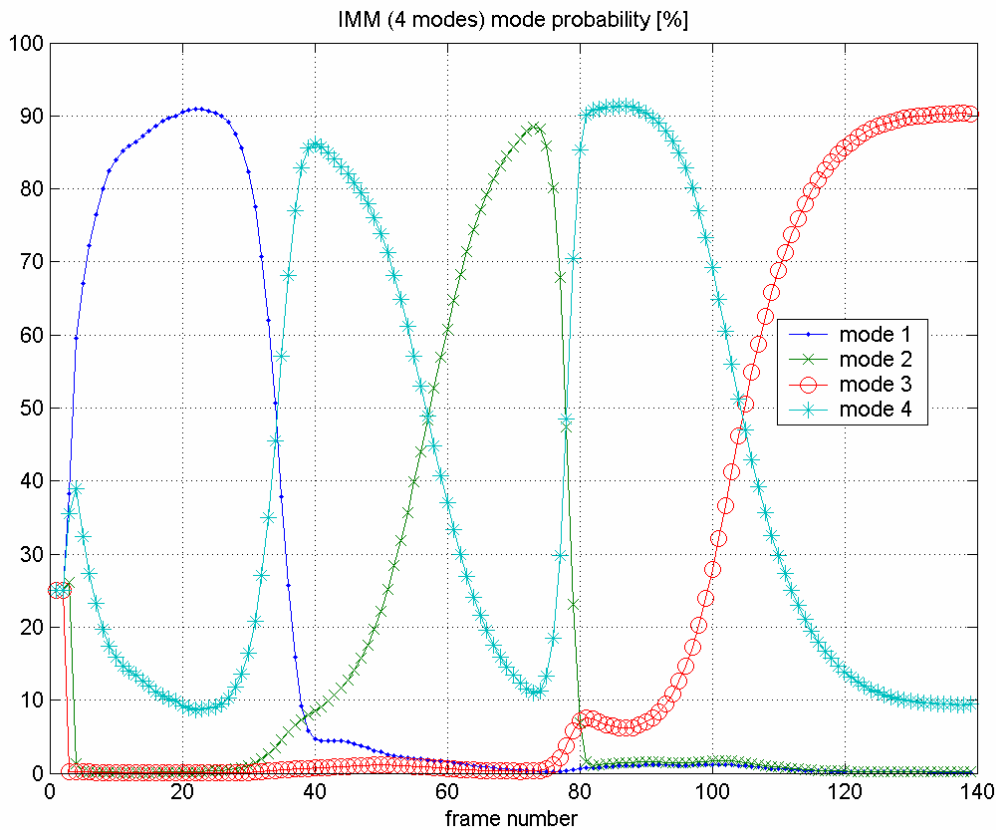

Figure 13: Mode Probabilities of IMM with Four Models along the Trajectory of Figure 10.

Figure 14 shows the mode probabilities of the IMM with seven models. The point marked, the cross marked and the circle marked curves, like the IMM with only four models, are associated respectively to the models matched to runway 2, taxiway 1 and taxiway 3; the plus sign marked and the triangle-right marked curves correspond to the models matched to the two manoeuvres performed by the aircraft; the triangle-left marked curve corresponds to a manoeuvre that is not performed and the asterisk marked curve is associated to the unconstrained model. It can be seen that the increased number of models does not always guarantee the selection of the model that best approximates the target kinematics. In particular, the results show two causes of performance degradation: when the target is crossing runway 1, the IMM uses the correct model only with the first plots, and it erroneously mixes the other models with the rest of the plots; the IMM gives a higher importance to the model approximating the first aircraft manoeuvre (plus sign marked curve) also when the aircraft is moving along taxiway 1 (cross marked curve).

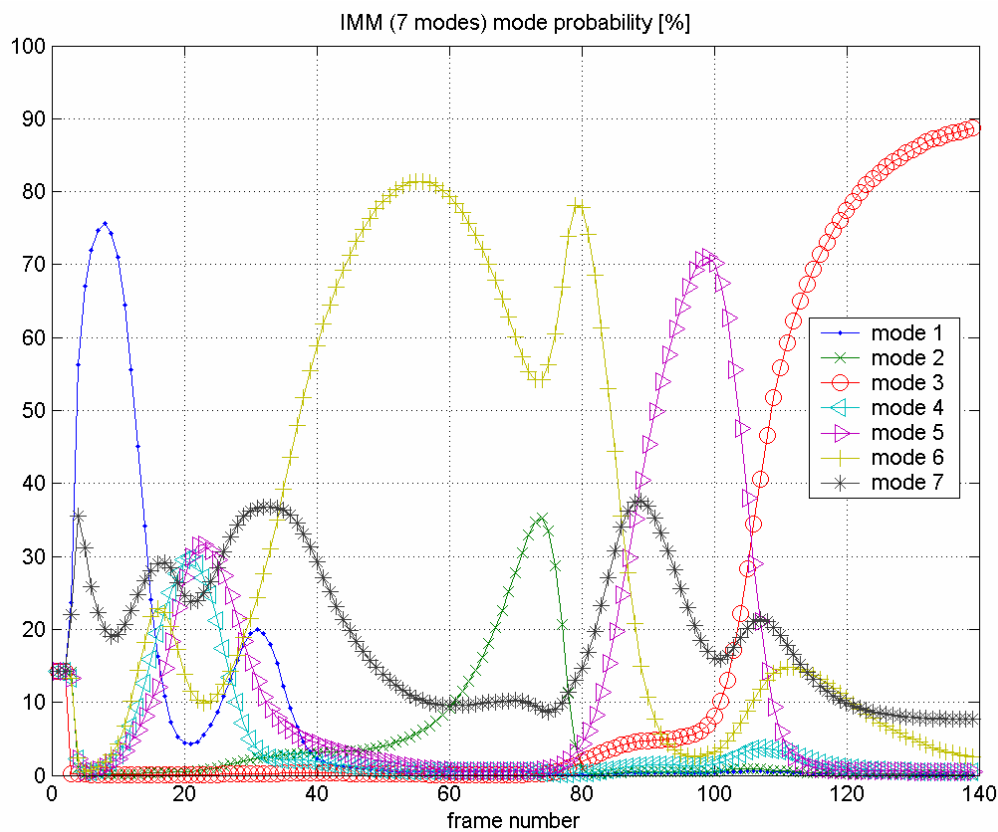

Figure 14: Mode Probabilities of IMM with Seven Models along the Trajectory of Figure 10.

Figure 15 shows the mode probabilities of the VS-IMM. The models and the marks are the same as the IMM. It can be seen that the map-based activity areas bring to a sensible improvement in the selection of the correct model with respect to the IMM with seven models. The VS-IMM has a behaviour similar to the IMM with four models when the target is crossing a runway or taxiway; when the target is manoeuvring, the VS-IMM, after using for a few plots the unconstrained model, selects the model that best approximates the target kinematics.

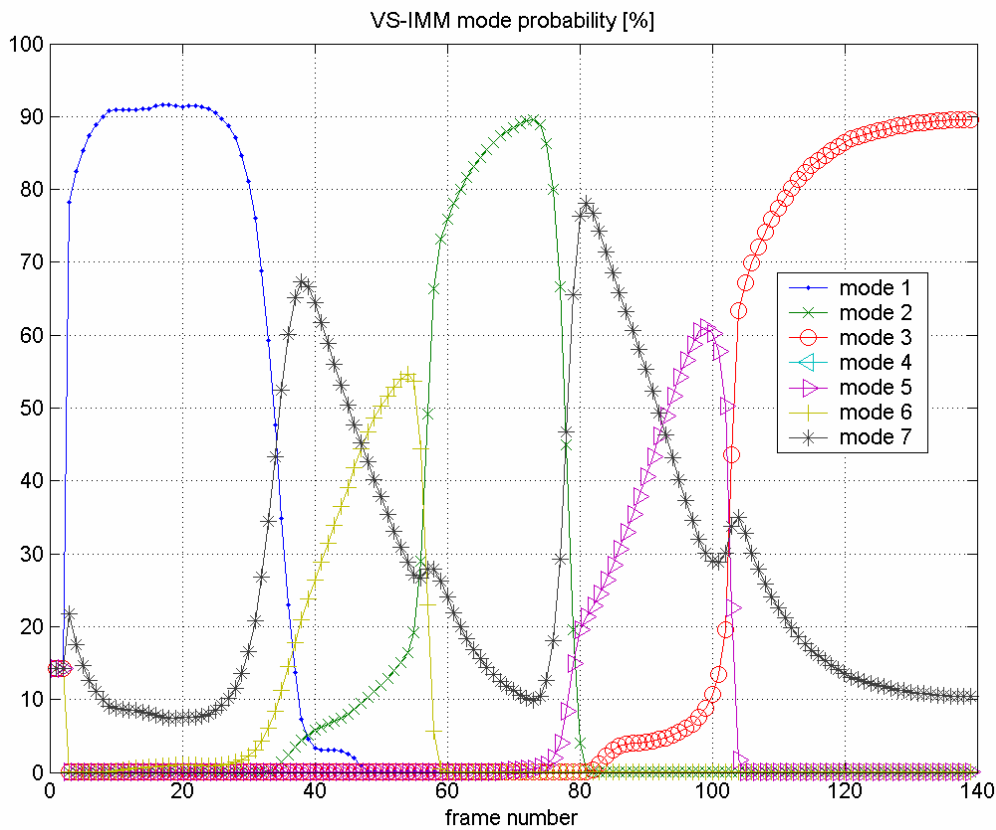

Figure 15: Mode Probabilities of VS-IMM along the Trajectory of Figure 10.

Figure 16 shows the standard deviations of the target position estimate along the x-coordinate. It can be noted that the IMM with four models and the VS-IMM estimation are more accurate than the EKF ones during the whole trajectory, thanks to the use of the constraints and to the correct selection of the models. The IMM with 7 models is instead less accurate than the EKF when the target is crossing runway 1, because of the incorrect selection of the model.

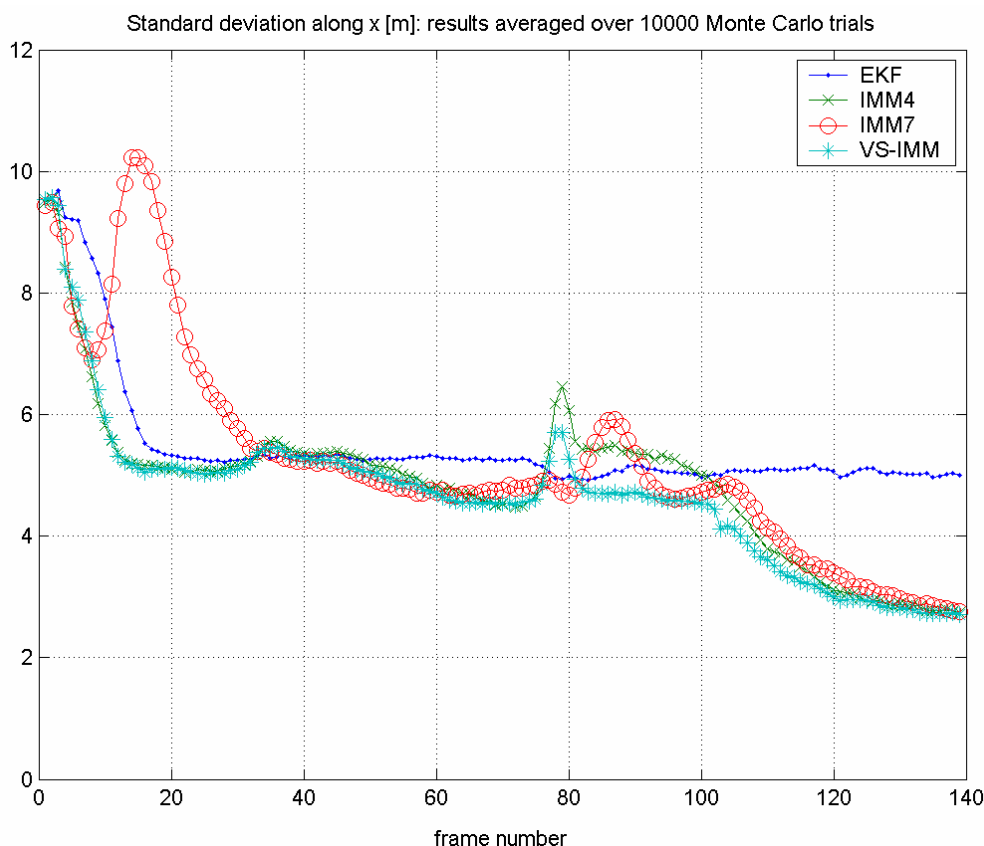

Figure 16: Standard Deviation (m) of the Target Position Error along the x-axis for the Trajectory of Figure 10.

In [58] a comprehensive set of performance curves is shown to display the standard deviations of the target velocity in polar coordinates (module and heading) and the target turn rate. It can be seen that the IMM with seven models is not always better than the EKF. The VS-IMM instead brings a sensible improvement along the whole trajectory with respect to all the other algorithms. The best estimation is definitely provided by the VS-IMM. The same reference describes also interesting results concerning the processing of recorded live data from Malpensa (It) airport.

In this section a map-based VS-IMM algorithm for the tracking of targets with the SMR data of the A-SMGCS has been proposed. The tracking algorithm has been tested and compared to an EKF and two IMM algorithms in a realistic simulated scenario and on real data. The obtained results demonstrate the benefits brought by the VS-IMM approach. The VS-IMM has shown a more effective management of the constrained models and better accuracy in the estimation of the target position, velocity and turn rate than the EKF and the IMM approaches.

5. APPLICATION TO GMTI

Airborne surveillance of ground moving or stationary vehicles using the GMTI (Ground Moving Target Indicator) radar was proved extremely successful from an operational point of view [60]. A number of large-scale programs have included the GMTI radar for tracking ground moving targets. The GMTI radar sensor

plays an important role in situation awareness of the battlefield, surveillance, and precision tracking of ground targets [54], [62]-[67]. A special Session on Ground Target Tracking and Classification (organised by M. Mallick and A. Marrs) is held during the Fusion 2003 Conference, Australia in July 8-11, 2003. Tracking of ground targets is far more complex than that of air targets due to the constraints imposed by the terrain, for which only uncertain data is available. Ground targets in many cases move on road networks [63] and avoid regions that are not-trafficable; but they can also move off-roads. This leads to finite support for the distribution of the target state. Therefore, popular filtering algorithms such as the KF with Gaussian distributions and the EKF for non linear filtering problems are not suitable in certain cases. GMTI radar platforms have a number of drawbacks; since the GMTI radar platform operates at a standoff distance from the surveillance area, the terrain, trees and buildings can often occlude the radar line-of-sight. Also GMTI data collection is usually interrupted during the turn of the aircraft. This Section summarises some techniques to build up tracks by exploiting GMTI radar data. This topic is a bit different from one previously discussed in Section 4; for instance, here the targets can manoeuvre and can move off-roads. Here we summarises the main finding of two key references [54] and [67].

Reference [54] is probably the first that has introduced the VS-IMM estimator for tracking groups of ground targets on constrained paths using GMTI data obtained from an airborne sensor. It is assumed that targets move along highways with varying obscuration due to changing terrain conditions. The roads can branch, merge and cross. Some of the targets may also move in open field. The key discovery illustrated in [54] is that the constrained motion estimation problem is handled using an IMM estimator with varying mode sets depending on the topography. The number of models, their types and their parameters are modified adaptively based on the estimated position of target and the corresponding road/visibility conditions. As said in [54], this topography based variable structure mechanism eliminates the need for carrying all the possible models throughout the entire tracking period as in the standard IMM estimator. The specification of the road map with visibility conditions can be summarised in a table which specifies each road segment, the waypoints, the visibility condition, the indication whether it is possible to enter or exit.

A working example is the following. In VS-IMM the filter modules are adaptively modified, added or removed depending on the terrain topography. For example, the added uncertainty at junctions is handled by temporarily augmenting the IMM mode set with modes that represent motion long all possible roads. These additional IMM modes are removed from the mode set after the target passes the junction. At each scan the structure of the estimator for every target is modified individually based on the known topology of the surveillance region and the predicted location of the target. This enables the estimator to handle the variations in the possible motions across the target and along time for each target.

Another issue that has been addressed in [54] is the plot-track association logic. Known algorithms are (see Section 2.2): NN, PDA, JPDA and MHT. Assignment algorithms are also effective in data association for multi-target tracking in clutter environment [61]. Here the data association is formulated as an optimisation problem where the cost function to minimise is a combined likelihood function of the estimated states. The association of the elements of the latest measurement to those in the track list is called assignment with time-depth 1 results in a two-dimensional assignment. A higher order assignment where the latest $S-1$ scans of measurements are associated with the established track list (from time $k-S+1$ where k is the current time, i.e., with sliding window of time depth $S-1$) results in a S -dimensional assignment [61]. In the context of constrained motion it is interesting to check whether higher order assignment yields better association by using topographic history, i.e. by considering not only the topography at the currently predicted position but also the conditions at the previously estimated positions of target. This brings to a VS-IMM based on multidimensional assignment. It has been shown that the S -dimensional assignment requires quasi-polynomial time for computation thus allowing the only systematic implementation of MHT [54].

Here we briefly summarise the mathematical model for on-road/off-road motion. Unlike an off-road-capable target, which is free to move in any direction, the motion of an on-road-only target is highly directional along the road. To handle the motion along the road the concept of directional noise is introduced in [54]. The standard motion model assumes that the target can move in any direction and, therefore, use equal process noise variances in both the x and y directions. This means that for off-road targets the motion uncertainties in both directions are equal. For on-road targets, the road constraint means more uncertainty along the road than orthogonal to it. Thus the IMM module representing on-road motion consists of process noise components along and orthogonal to the road, rather than along x and y directions as in the standard model. Indicating with ψ , measured from the y axis, the direction of the road along which the motion model is matched, indicating with σ_a and σ_0 the standard deviations of the process noise components along the road and orthogonal to the road, we have: $\sigma_a \gg \sigma_0$ which contrasts with the $\sigma_x = \sigma_y$ for off-road motion model. Since the estimate is carried out in x-y coordinates, the variances of the process noise components of along and orthogonal to the road need to be converted into a covariance matrix \mathbf{Q} in that frame:

$$\mathbf{Q} = \begin{bmatrix} -\cos \psi & \sin \psi \\ \sin \psi & \cos \psi \end{bmatrix} \begin{bmatrix} \sigma_0^2 & 0 \\ 0 & \sigma_a^2 \end{bmatrix} \begin{bmatrix} -\cos \psi & \sin \psi \\ \sin \psi & \cos \psi \end{bmatrix} \quad (11)$$

The same references also presents models for junctions, entry/exit conditions and obscuration condition.

Simulation results refer to a complex scenario with a network of roads and 120 targets in nine groups of different characteristics [54]. Four algorithms are compared: IMM with 2-D and 3-D assignment and VS-IMM with 2-D and 3-D assignment. The performance clearly show that the best is the VS-IMM with 3-D assignment followed by the VS-IMM with 2-D assignment. The fixed IMM which consisted of two baseline models in addition to a third second order model performed worse than the VS-IMM. This is because the VS-IMM is able to handle the on-road/off-road transition and the change from one road to another more smoothly than the fixed IMM by anticipating the changes. Also, once that the target begins to move along a particular road, the VS-IMM, which uses a model matched to the road, yields better course estimate than the fixed IMM which uses an open field model.

Reference [67] tackles the problem of incorporating non standard information (road maps and terrain related visibility conditions) by resorting to the PF (see Section 2.3). Exploiting non-standard information leads to highly non Gaussian pdf and conventional trackers do not properly work. Since PF has no restrictions on the types of models, including noise distributions used, one can incorporate non-standard information available through maps and velocity constraints by modelling them as suitable constraints on the state. As said in Section 2.3, PF is routinely used for recursive state estimation; extension to MM has also been reported in the recent literature. Reference [67] combines the VS-IMM concept with the PF technique giving rise to the new algorithm called variable structure multiple model particle filter (VS-MMPF). The key features of the VS-MMPF are that the number of models active at any particular time and the state transitions vary depending on the current state and the topography. Simulation results compare the VS-IMM and the VS-MMPF for a single target moving on a network of roads. It is shown that VS-MMPF provides 65% improvement in tracking accuracy with respect to the VS-IMM for a road target. With speed constraints knowledge the advantage in rms error grows up to 77% [67].

6. APPLICATION TO TRACKING OF TARGETS HIDDEN IN BLIND DOPPLER

This section is fully derived by [68] with permission of the Authors. Most combat aircraft are equipped with some form of electronic warfare intelligence system, such as electronic support measures (ESM) or a radar warning receiver (RWR). These systems in general detect nearby RF emissions, process them in real-time, and report to the pilot the direction of arrival of each RF emission and the identity of its source. In a hostile environment, there are various electronic protection (EP) measures available to the pilot that can hide the aircraft's true position from the enemy radar, such as noise jamming, deceptive ECMs, chaff, etc. One of the simplest and most effective EP measures against any CW or pulse Doppler radar is to hide in the radar Doppler blind zone (DBZ). The blind Doppler are the bands of Doppler frequency falling within the MTI rejection notches covering the regions around zero Doppler and the integer multiples of the PRF. MTI filters out the ground clutter and the ground moving targets from the radar echoes. MTI cut-off frequency can be up to plus or minus 80 knots in airborne radars. Hiding in the blind Doppler is aided by the on-board ESM or the RWR, since either system indicates to the pilot the direction of the enemy radar. The pilot can then manoeuvre to reduce the aircraft's radial velocity by flying tangentially with respect to the enemy radar. Hiding in the blind Doppler is only a temporary measure, but it often causes a loss of track. Once the target comes out of the blind Doppler a new track has to be initiated and the target has to be again identified. By the time the new track is established, the target could be lost again because it hides once again in the blind Doppler. With the standard Kalman-type filters it is difficult to exploit prior knowledge of the geographical or sensor limitations, such as the position extent of the blind Doppler zones. These effects introduce gross non linearity in the form of "hard edges" on probability distributions. The "hard constraints", however, can be fairly easily incorporated into the framework of sequential Monte Carlo (SMC) estimation techniques. Reference [68] compares two filters, the EKF and the PF, for tracking an airborne target which temporarily hides in the DBZ. Both filters assume a constant velocity target motion with some process noise to handle the possible maneuvers. The EKF is tracking the target using only radar measurements (target range, azimuth, and range rate obtained from Doppler). The PF, in addition to the radar measurements, exploits prior knowledge of the DBZ limits.

The true target state at a discrete time t_k is $s_k = [x_k \quad \dot{x}_k \quad y_k \quad \dot{y}_k]^T$, where x_k, y_k are the position and \dot{x}_k, \dot{y}_k are the velocities of the target in Cartesian coordinates. The polar measurements of the target location at t_k (range r_k and azimuth θ_k), obtained from a radar, are conveniently converted into the Cartesian system [14]. The target motion model is the constant velocity (CV) model, with an appropriate level of process noise to deal with possible maneuvers. The state dynamics is linear equation; while the measurement equation is non linear because of the presence of the radial speed \dot{r}_k [68]. The detection probability of radar is as follows:

$$P_D(s_k) = \begin{cases} P_d \rightarrow \text{if} : \left| \frac{x_k \dot{x}_k + y_k \dot{y}_k}{\sqrt{x_k^2 + y_k^2}} \right| \geq L_0 \\ 0 \rightarrow \text{otherwise} \end{cases} \quad (12)$$

where L_0 is the limit of the DBZ and P_d is a positive constant less than or equal to unity (i.e.: the actual radar detection probability when the target is visible). The problem is to investigate the performance of a standard EKF, which ignores the existence of the DBZ, against the PF which uses the prior knowledge of L_0 in eq. (12). The latter was developed using SMC techniques mainly because any nonstandard form of information (such as prior knowledge of L_0) can be easily incorporated into the framework of SMC estimation.

In [68] a PF is outlined which allows information about the DBZ limits to be directly utilized in the tracking process. By doing this we have a situation where receiving no measurement actually conveys useful

information about the probable target location and velocity. A string of periods with no measurement is then strongly indicative of a target maneuvering in the blind zone and the particles spread out to cover the possible trajectories and locations where this is possible and effectively wait for the target to appear out of the blind zone. Hence we expect increased probability of track maintenance. The basic idea to build the PF is to have one set of particles restricted to motion within the DBZ and the other set able to move unrestricted. The two sets of particles are used to hedge between the two possible motions. Details and pseudo-code of the PF are in [68].

The performance of the candidate algorithms is measured by the probability of track maintenance; Monte Carlo simulation is run to make these evaluations. To define a track loss, a track score S is suitably defined [68]. The following target trajectory is considered (see Figure 17). The target is at first going radially toward the radar at a speed of 800 km/h. Then it makes a 3g turn to its right and continues the tangential motion with respect to radar for about 25 s. Finally the target makes another 3g turn and moves again towards the radar with a high range-rate. Note that while the target is in the DBZ (the second leg of the target motion), there are no target measurements. The parameters of the radar model used in simulation are as follows: the sampling interval is $T_s=2$ s; the error statistics for radar measurements are $\sigma_r = 250m$, $\sigma_{\dot{r}} = 3m/s$, and $\sigma_{\theta} = 1^\circ$; the DBZ limit is $L_0=100$ km/h; the probability of detection is $P_d=0.9$. Note that the track score is calculated in such a way that if the first measurement after the reappearance of the target from the DBZ is not gated, the track is lost. In the Monte Carlo run concerning the EKF, not shown here, the track has been lost [68]. Figure 17 illustrates the result obtained with the PF. Because of the proper shape of the validation region, the first measurement after the reappearance of the target from the DBZ falls inside the gate of the particle filter. The shape of this gate, just before the crucial moment (at time 108 s) is indicated by a cloud of particles in Figure 17a. Note that the shape of the cloud (which resembles an arc) accurately represents the uncertainty associated with the target position. As a result, the PF does not lose the track – the track score S_k , after dipping to the value of 0.1 recovers quickly to 1 which is its maximum allowed value. Additional interesting simulation results are reported in the key reference [68].

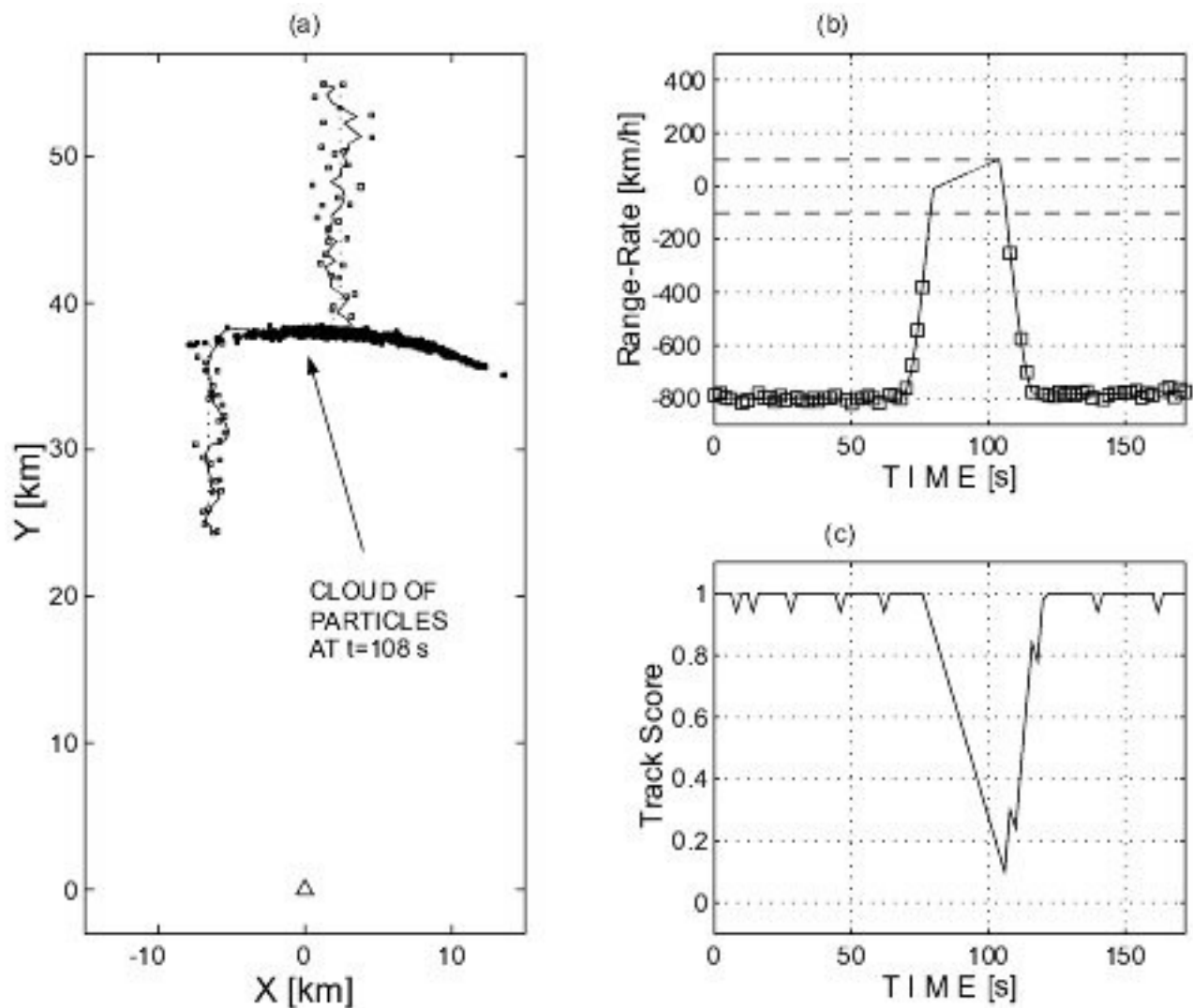

Figure 17: The PF in Action: (a) State Estimation (solid line) with a Cloud of Particles at t=108 s; (b) the Range-Rate; (c) the Track Score S_k (reproduced from [68] with permission of the Authors N. Gordon, B. Ristic).

The problem of tracking a target occasionally bidden in the blind Doppler of a radar has been investigated. It has been demonstrated that by using prior knowledge of the limits of the DBZ, one can design a tracker which will perform better, in terms of track continuity, than a tracker which ignores this prior information. The concept has been proven using a particle filter, mainly because any non standard information (such as blind Doppler) can be easily incorporated into the framework of sequential Monte Carlo estimation.

7. CONCLUSIONS

In this paper we have described the new technique of knowledge based tracker (KBT). After an extensive review of the state of the art of tracking system, attention has been put on the use of a-priori knowledge in designing a tracking filter with the aim of improving tracking performance. Three application examples have

been presented to illustrate the efficacy of KBT. Other applications are of interest like the use of geographic map for radar tracking in littoral environment (i.e.: near the coast-line).

8. ACKNOWLEDGEMENTS

The author expresses his thanks to the following colleagues: G. Golino and L. Ferranti (AMS, Italy), B. Ristic and N. Gordon (DSTO, Australia), S. Coraluppi (NATO-SACLANT, Italy) for co-operation in some of the paper topics.

9. REFERENCES

- [1] F.C. Gauss, “Theoria motus corporum coelestiorum in sectionibus conics solem ambientum”, Hamburg, 1809 (translation: Dover, New York, 1963).
- [2] A.M. Legendre, “Methode de moindres quarres pour trouver le milieu le plus propable entre les resultats des differentes observations”, Mem. Inst. France, pp. 149-154, 1810.
- [3] R.A. Fisher, “On an absolute criterion for fitting frequency curves”, Messenger of Math., pp. 41-155, 1912.
- [4] A.N. Kolmogorov, “*Foundations of the theory of probability*”, Spinger, New York, 1933.
- [5] N. Wiener, “*Extrapolation, interpolation, and smoothing of stationary time series*”, Cambridge, MA, Technology Press and New York, Wiley, 1949.
- [6] N. Wiener, “*Non linear problems in random theory*”, Cambridge, MA, Technology Press and New York, Wiley, 1958.
- [7] C.W. Therrien, “The Lee-Wiener Legacy”, IEEE Signal Processing Magazine, November 2002, pp. 33-44.
- [8] N. Levinson, “The Wiener root-mean-square error criterion in filter design and prediction”, J. Math. Phys., vol. 25, pp. 261-278, 1947.
- [9] R.E. Kalman, “A new approach to linear filtering and prediction problems”, Journal of Basic Eng., Trans. ASME, Ser. D, vol. 82, no. 1, pp. 35-45, 1960.
- [10] R.E. Kalman, R.S. Bucy, “New results in linear filtering and prediction theory”, Journal of Basic Eng., Trans. ASME, Ser D, vol. 83, no. 3, pp. 95-108, 1961.
- [11] T. Kailath, “A view of three decades of linear filtering theory”, IEEE Trans. On Information theory, vol. IT-20, no. 2, pp. 146-179, 1974.
- [12] R. Kalman biography: http://www.math.rutgers.edu/~sontag/ftp_dir/rek.
- [13] E. Brookner, “*Tracking and Kalman filtering made easy*”, Wiley Interscience, 1998.
- [14] A. Farina, F.A. Studer, “*Radar Data Processing. Introduction and Tracking*” (Vol. I). Researches Studies Press. England, May 1985.

- [15] H. Blom, Y. Bar-Shalom, "The interacting multiple model algorithm for systems with Markovian switching coefficients", *IEEE Trans. on Automatic Control*, vol. AC-33, pp. 780-783, August 1988.
- [16] X.R. Li, "Engineer's guide to variable-structure multiple-model estimation for tracking. Ch. 10", <http://ece.engr.uno.edu/isl/PublicationsBySubjects.htm>.
- [17] M. De Feo, A. Graziano, R. Miglioli, A. Farina, "IMMJPDA versus MHT and Kalman filter with NN correlation: performance comparison". *IEE Proceedings on Radar, Sonar and Navigation (Pt. F)*, vol. 144, no. 2, April 1997, pp. 49-56.
- [18] R. Graziano, R. Miglioli, A. Farina, "Multiple hypothesis tracking vs. Kalman filter with nearest neighbor correlation. Performance comparison". *AGARD MSP 3rd Symposium on "Tactical Aerospace C³I in Coming Years"*, Lisbon, Portugal, 15-18 May 1995, published in CP-557, pp. 25-1, 25-11.
- [19] R. Torelli, A. Graziano, A. Farina, "IM³HT algorithm: a joint formulation of IMM and MHT for multitarget tracking". *Invited Paper*, *Proceedings of European Control Conference, ECC97*, Vol. 3 "Estimation", Pt.1 WE-A F1, p. 750, Bruxelles, July 1-4, 1997.
- [20] R. Torelli, A. Graziano, A. Farina, "IM³HT algorithm: A joint formulation of IMM and MHT for multi-target tracking", *European Journal of Control*, vol. 5, 1999, pp. 46-53.
- [21] A. Farina, P. Lombardo, M. Marsella, "Joint tracking and identification algorithms for multisensor data", *Proc. of IEE, RSN*, vol. 149, no. 6, December 2002, pp. 271-280.
- [22] A. Farina, F.A. Studer, "*Radar Data Processing. Advanced Topics and Applications*" (Vol. 2). Researches Studies Press, England, January 1986.
- [23] A. Farina, "Sensor netting for surveillance and use of related emerging technologies". *Proc. of the 1987 Rome AFCEA European Symposium*, May 6-8, 1987, pp. 49-57.
- [24] A. Farina, "Tracking function in bistatic and multistatic radar systems". *Special issue on bistatic and multistatic radar, IEE Communication, Radar and Signal Processing, Pt. F, Vol. 133, no. 7, December 1986*, pp. 630-637.
- [25] A. Farina, B. La Scala, "Methods for association of active and passive tracks for airborne sensors". *International Symposium on Radar, IRS98, Munich, 15-17 September 1998*, pp. 735-744.
- [26] A. Farina, R. Miglioli, "Association between active and passive tracks for airborne sensors". *Signal Processing*, 69, 1998, pp. 209-217.
- [27] B. La Scala, A. Farina, "Effects of cross-covariance and resolution in track association", *3rd Intl. Conference on Fusion, Fusion 2000, Paris, July 10-13, 2000*, pp. WeD1-10 to WeD1-16.
- [28] B. La Scala, A. Farina, "Choosing a track association method", *Information Fusion Journal*, vol. 3, issue 2, June 2002, pp. 119-133.
- [29] A. Farina, B. Ristic, D. Benvenuti, "Tracking a ballistic target: comparison of several non linear filters", *IEEE Trans on Aerospace and Electronic Systems*, vol. 38, issue no. 3, July 2002, pp. 854-867.

- [30] B. Ristic, A. Farina, D. Benvenuti, "Tracking a ballistic re-entry object: performance bounds and comparison of non-linear filters", IDC-2002, Adelaide, Australia, 11-13 February 2002, pp. 259-264.
- [31] A. Farina, D. Benvenuti, B. Ristic, "Estimation accuracy of a landing point of a ballistic target", Proc. of Intl. Conf. Fusion 2002, Washington DC, May 2002, pp. 2-9.
- [32] B. Ristic, A. Farina, D. Benvenuti, M. S. Arulampalam, "Performance bounds and comparison of non-linear filters for tracking a ballistic object on re-entry", Proc. of IEE, RSN, to appear, 2003.
- [33] A. Farina, "Target tracking with bearings-only measurements". Signal Processing, vol. 78, no. 1, October 1999, pp. 81-78.
- [34] A. Farina, D. Benvenuti, B. Ristic, "A comparative study of the Benes filtering problem", Signal Processing, vol. 82, no. 2, February 2002, pp. 133-147.
- [35] S. Julier, J. Uhlmann, H. F. Durrant-Whyte, "A new method for the non linear transformation of means and covariances in filters and estimators", IEEE Trans. on Automatic Control, vol. AC-45, no. 3, pp. 477-482, March 2000.
- [36] N. Gordon, D. Salmond, A. Smith, "Novel approach to nonlinear/nonGaussian Bayesian state estimation", IEE Proc. F, Radar Signal Process, 1993, vol. 140, no. 2, pp. 107-113.
- [37] M.S. Arulampalam, S. Maskell, N. Gordon, T. Clapp, "A tutorial on particle filters for on line nonlinear/nonGaussian Bayesian tracking", IEEE Trans. on Signal Processing, vol. 50, no. 2, February 2002, pp. 174-188.
- [38] A. Doucet, N. de Freitas, N. J. Gordon, editors, "*Sequential Monte Carlo methods in practice*", New York: Springer-Verlag, January 2001.
- [39] C. Musso, N. Oudjane, F. Legland, "Improving regularised particle filters", in [38].
- [40] C. Hue, J.-P. Le Cadre, P. Perez, "Sequential Monte Carlo methods for multiple target tracking and data fusion", IEEE Trans. on Signal Processing, vol. 50, no. 2, pp. 309-325.
- [41] N. Gordon, D. Salmond, "Sequential Monte Carlo methods for tracking", at an IEE Colloquium on Kalman filtering – applications and pitfalls, March 2001. Available on the WWW.
- [42] F. Daum, J. Huang "Curse of dimensionality and particle filters", Proc. of the IEEE Aerospace Conference, Big Sky, Montana (USA), March 2003.
- [43] P. Tichavsky, C. Muravchik, A. Nehoray, "Posterior Cramer-Rao bounds for discrete-time nonlinear filtering", IEEE Trans on Signal Processing, vol. 46, 1998, pp. 1386-1396.
- [44] M. Simandl, J. Kralovec, P. Tichavsky, "Filtering, predictive, and smoothing Cramer-Rao bounds for discrete-time nonlinear dynamic systems", Automatica, vol. 37, 2001, pp. 1703-1716.
- [45] A. Farina, B. Ristic, L. Timmoneri, "Cramer-Rao bound for nonlinear filtering with $P_d < 1$ and its application to target tracking", IEEE Trans on Signal Processing, Vol. 50, issue 8, August 2002, pp. 1916-1924.

- [46] Y. Bar-Shalom, T. Fortmann, "Tracking and data association", Academic Press, 1988.
- [47] S. Blackman, "*Multiple-target tracking with radar applications*", Artech House, 1986.
- [48] Y. Bar-Shalom, X-Rong Li, "*Multitarget-multisensor tracking: principles and techniques*", YBS, 1995.
- [49] P. Bogler, "*Radar principles with applications to tracking systems*", John Wiley & Sons, New York, January 1990.
- [50] D. Halls, J. Llinas, "*Handbook of multisensor data fusion*", CRC, 2001.
- [51] Y. Salama, R. Senne, "Knowledge-based applications to adaptive space-time processing. Volume I: Summary", AFRL-SN-TR-2001-146 Vol. I (of Vol. VI), Final Technical Report, July 2001.
- [52] C. Morgan, L. Moyer, "Knowledge-based applications to adaptive space-time processing. Volume IV: Knowledge-based tracking", AFRL-SN-TR-2001-146 Vol. IV (of Vol. VI), Final Technical Report, July 2001.
- [53] C. Morgan, L. Moyer, "Knowledge-based applications to adaptive space-time processing. Volume IV: Knowledge-based tracking rule book", AFRL-SN-TR-2001-146 Vol. V (of Vol. VI), Final Technical Report, July 2001.
- [54] T. Kirubarajan, Y. Bar Shalom, K. R. Pattipati, I. Kadar, "Ground target tracking with variable structure IMM estimator", IEEE Trans. on Aerospace and Electronic Systems, vol. 36, no. 1, January 2000, pp. 26-46.
- [55] D. Simon, T.L. Chia, "Kalman filtering with state equality constraints", IEEE Trans. on Aerospace and Electronic Systems, vol. 38, no. 1, January 2002, pp. 128-136.
- [56] S. Coraluppi, C. Carthel, "Multiple-Hypothesis IMM (MH-IMM) filter for moving and stationary targets", Proc. Fourth International Conference on Information Fusion, August 2001, Montreal, Canada.
- [57] X.R. Li, Y. Bar Shalom, "Multiple Model Estimation with Variable Structure" IEEE Trans. on Automatic Control, vol. 41, no. 4, April 1996.
- [58] A. Farina, L. Ferranti, G. Golino, "Constrained tracking filters for A-SMGCS", Proc. of Fusion 2003, July 8-11, 2003, Cairns, Queensland, Australia.
- [59] F. Gustafsson, A.J. Isaksson, "Best choice of coordinate system for tracking coordinate turns", Preprints 35th IEEE CDC, pp. 3145-3150, Kobe, Japan, 1996.
- [60] J.N. Entzminger, Jr., C.A. Fowler, and W.J. Kenneally, "JointSTARS and GMTI, past, present and future", IEEE Trans. Aerospace and Electronic Systems, Vol. 35, pp. 748-761, April 1999.
- [61] S. Deb, M. Yeaddanapudi, T. Kirubarajan, K.R. Pattipati, Y. Bar-Shalom, "A generalised S-dimensional assignment for multi-sensor multitarget state estimation", IEEE Trans. Aerospace and Electronic Systems, Vol. 33, no. 2, pp. 523-538, April 1997.
- [62] T. Kirubarajan, Y. Bar-Shalom, "Tracking Evasive Move-Stop Targets with and MTI Radar Using a VS-IMM Estimator", Signal and Data Processing of Small Targets: Proc. SPIE, Vol. 4048, pp. 236-246, Orlando, FL, April 2000.

Application of Knowledge-Based Techniques to Tracking Function

- [63] T. Kirubarajan, Y. Bar-Shalom, K.R. Pattipati, I. Kadar, B. Abrams, E. Eadan, "Tracking ground targets with road constraints using an IMM estimator", Proc. IEEE Aerospace Conference, March 1998.
- [64] S. Coraluppi and C. Carthel, "Multiple-Hypothesis IMM (MH-IMM) Filter for Moving and Stationary Targets", Proc. Fourth International Conference on Information Fusion, August 2001, Montreal, Canada.
- [65] M. Mallick, "Maximum Likelihood Geolocation using a Ground Moving Target Indicator (GMTI) Report", Proc. IEEE Aerospace Conference, March 2002, Big Sky MT, USA.
- [66] M. Mallick and Y. Bar-Shalom, "Nonlinear Out-of-sequence Measurement Filtering with Applications to GMTI Tracking", Signal and Data Processing of Small Targets: Proc. SPIE, Vol. 4048, Orlando, Florida, April 2002.
- [67] M. S. Arulampalam, N. Gordon, Orton, B. Ristic, "A variable structure multiple model particle filter for GMTI tracking". Proceedings of the Fifth International Conference on Information Fusion. FUSION 2002. (IEEE Cat.No.02EX5997). Int. Soc. Inf. Fusion. Part vol.2, 2002, pp. 927-34 vol.2. Sunnyvale, CA, USA.
- [68] N.J. Gordon, B. Ristic, "Tracking airborne targets occasionally hidden in the blind Doppler", Digital Signal Processing, vol. 12, no. 2/3, April/June2002, pp. 383-393.